



P/A INDUSTRIES INC.

522 Cottage Grove Road • Bloomfield, Connecticut 06002 U.S.A. • Web: www.pa.com
Telephone: 860-243-8306 • Fax: 860-242-4870 • Email: sales@pa.com

Medium Duty Stock Reels

Motorized and Drag Models: SRA 1612, 2516, 4524, 6512, 6524, 6536

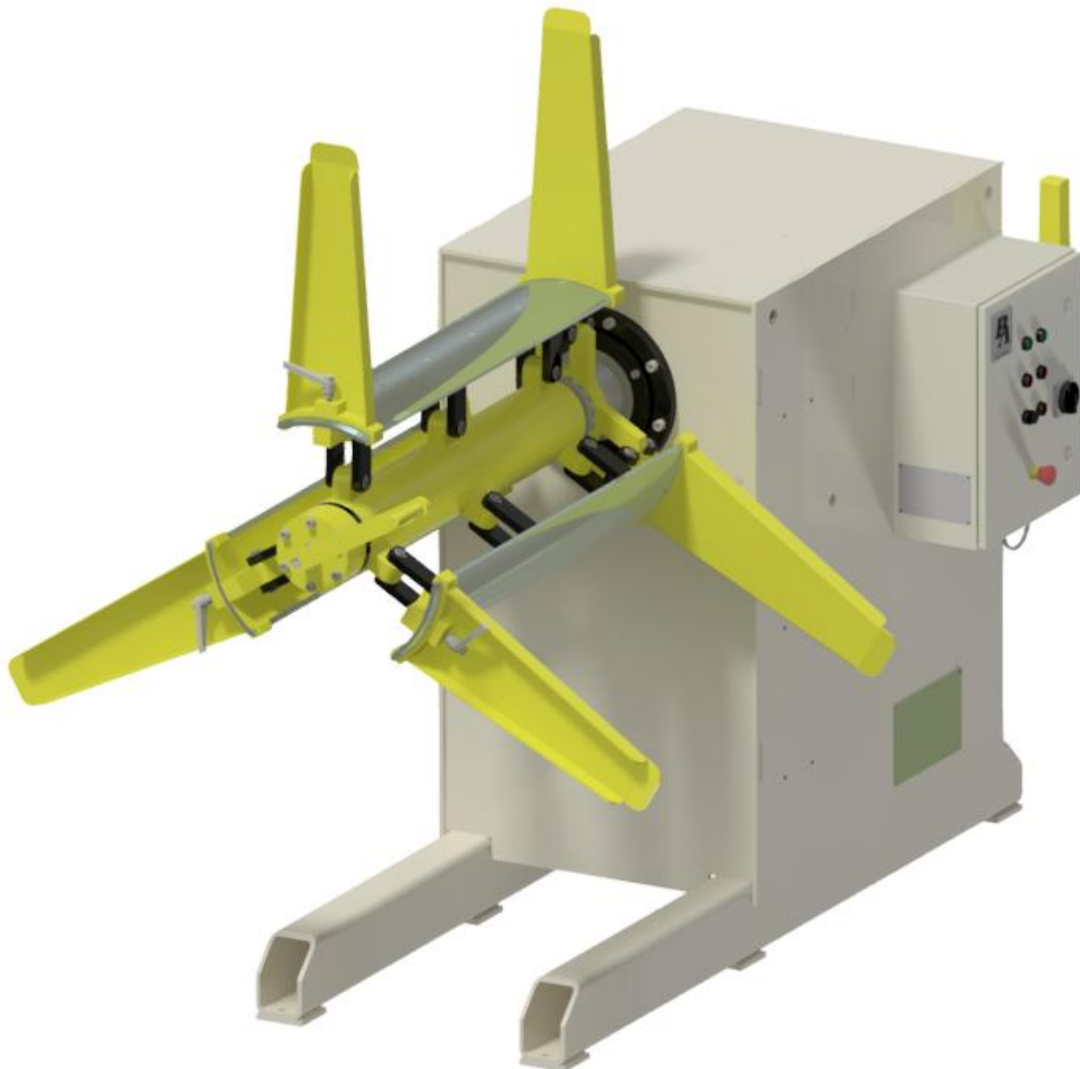

Table of Contents

- 1 Introduction 3**
 - 1.1 *General Safety program* 3
 - 1.2 *Warning*..... 3
 - 1.3 *Warranty Program* 4
 - 1.4 *Receiving and Inspection*..... 4

- 2 Installation and Assembly 5**
 - 2.1 *Mechanical* 5
 - 2.2 *Electrical* 5

- 3 Setup and Operation..... 5**

- 4 Maintenance 6**
 - 4.1 *Mechanical* 6

- 5 Specifications 7**
 - 5.1 *Overall Model Specifications* 7
 - 5.2 *Parts List* 7
 - 5.3 *Overall Dimensions & Drawings*..... 9
 - 5.4 *VFD Status / Warning Messages*..... 13

Thank you for selecting our product for your coil handling needs. This manual will provide you with all the information necessary to install, operate, apply and maintain your machine. Safety is always a priority so please follow all the caution and warning stickers labeled on our machines.

1 Introduction



Please read this manual thoroughly before installing, operating, applying and maintaining this machinery. Failure to do so may result in serious injury to yourself and/or others.

1.1 General Safety program

Accident free operation will result from a well developed, management sponsored and enforced safety program. Of vital importance to any successful program is the proper selection of guards and devices.

However, there is no safety device that will bring “automatic” safety to your operation.

Of equal importance to this proper selection of the guard and the device is the training of your personnel. Each person must be trained as to the operation of the guard or safety device, highlighting why they have been provided on the equipment. Rules for safe operating should be written and enforced at all times. A final major concern of an effective safety program is regularly scheduled inspection and maintenance of all of the equipment.

To ensure continued safety at all times, top management, line supervision, safety engineers and all employees must assume their proper share of the responsibility in the program. Only as a group, one that knows your own operation and its problems, can you carry out an effective safety program.

To assist you in the development of and continued use of safety programs, many safety minded groups have made guidelines available to you. However, you must know when and how to apply these guidelines. The manufacturer provides information to assist you in properly adjusting and maintaining your equipment. There is no short cut to proper safety; therefore, it is recommended that you comply with their recommendations at all times.

1.2 Warning

This equipment offers various means of operating or controlling machines. The operator must not be in or near the point-of-operation of the machine, or the operating parts of any equipment installed on the machine, or bodily injury could result. The EMPLOYER must post adequate warning signs onto the machine with proper warnings for his machine and the specific application to which the machine and equipment are being applied. Occupational Safety and Health Act (OSHA) Sections 1910.211, 1910.212, and 1910.217 contain installation information on the distance between danger points and point-of-operation guards and devices. No specific references have been made to which paragraph of OSHA 1910.211, 1910.212, 1910.217 or any other applicable sections because the paragraphs may change with each edition of the publication of OSHA provisions. All equipment manufactured by us is designed to meet the construction standards of OSHA in effect at the time of sale, but the EMPLOYER installs the equipment so the EMPLOYER is responsible for installation, use, application, training, and maintenance, as well as adequate signs on the machine onto which this equipment will be installed. Remember, OSHA says that the EMPLOYER must use operating methods designed to control or eliminate hazards to operating personnel. It shall be the responsibility of the EMPLOYER to establish and follow a program of periodic and regular inspections of his machine to insure that all their parts, auxiliary equipment, and safeguards are in a safe operating condition and adjustment. Each machine

should be inspected and tested no less than weekly to determine the condition of the machine. Necessary maintenance or repair of both shall be performed and completed before the machine is operated. The EMPLOYER shall maintain records of these inspections and the maintenance work performed. Our Company is not responsible to notify the user of this equipment of future changes in State or Federal laws, or construction standards.

1.3 Warranty Program

We warrant our new parts against defects under normal use and service for a period of 12 months after date of shipment. Our obligation under this warranty is limited to replacing or repairing (at our option) the defective part without charge, F.O.B. our plant in Bloomfield, Connecticut. The defective part must be forwarded to our plant, freight prepaid, for our inspection prior to replacement or repair. **EXCEPT AS EXPRESSLY PROVIDED HEREIN, THIS WARRANTY IS IN LIEU OF ALL OTHER WARRANTIES, EXPRESS OR IMPLIED, INCLUDING A WARRANTY OF MERCHANTABILITY OR FITNESS FOR A PARTICULAR PURPOSE.**

Furthermore, the seller does not warrant or represent that the equipment complies with the provisions of any law, particularly including the Occupational Safety and Health Act of 1970, and regulations promulgated there under. In no event shall we be liable for special, indirect incidental or consequential damages, however rising.

1.4 Receiving and Inspection

SPECIAL NOTE: P/A INDUSTREIS INC. ASSUMES NO RESPONSIBILITY IN CONNECTION HEREWITH, NOR CAN IT BE ASSUMED THAT ALL ACCEPTABLE SAFETY MEASURES ARE CONTAINED IN THIS PUBLICATION, OR THAT OTHER ADDITIONAL MEASURES MAY NOT BE REQUIRED UNDER PARTICULAR OR EXCEPTIONAL CIRCUMSTANCES OR CONDITIONS.

RECEIVING INSPECTION

Before removing the unit from its packaging, check for visual damage, especially if crate, skid, or carton had been damaged in transit. Any damage caused by shipping should be immediately reported to the carrier. If the unit appears in satisfactory condition, remove all the packaging. Read these instructions. They are provided to answer questions regarding the Operation and use of this equipment.

2 Installation and Assembly

2.1 Mechanical

Place the PA Adjustable Stock Reel so that the centerline of the coiled material is in line with the centerline of the press and remaining process equipment.

Warning:

The fixed base must be lagged to the floor. To prevent accidental tipping of the unit, minor dislocation from its working spot by bumping from coil handling equipment or from banging the unit against its mechanical stop during turn around with a heavy coil on the reel.

2.2 Electrical

See schematic.

3 Setup and Operation

Caution:

The crank handle must be removed from the inner shaft extension before rotating an idle reel into working position.

The machine is equipped with a **dancer arm speed control system**. The speed is zero at rest and increases as the dancer arm is lifted up.

To accommodate shipping, this dancer arm is detached, and must be re-attached when the machine is undergoing installation.

The dancer arm **MUST** be positioned such, that the roller end faces toward the press and is secured onto the knurled shaft with the supplied clamp block.

The height of the dancer arm should be set so that it rests in a horizontal position when the knurled shaft is against the **rotational stop**.

NOTE: The dancer arm must be set low enough so that when the turret is rotated, it does not obstruct the rotation of the coil and coil keepers.

The machine is operated using the commands on the control box and jog pendant.

CONTROL/DEVICE	DESCRIPTION
Power On/Reset button	Turns controller on; resets the AC drive.
Start/Stop button	Allows the reel to unwind by instruction from the dancer arm; ceases movement of the reel.
For/Rev button	Changes the direction of the mandrel.
Emergency Stop red mushroom button	Shuts controller off.
Jog Pendant	Jogs the mandrel in either direction via the For (Forward) and Rev (Reverse) buttons.

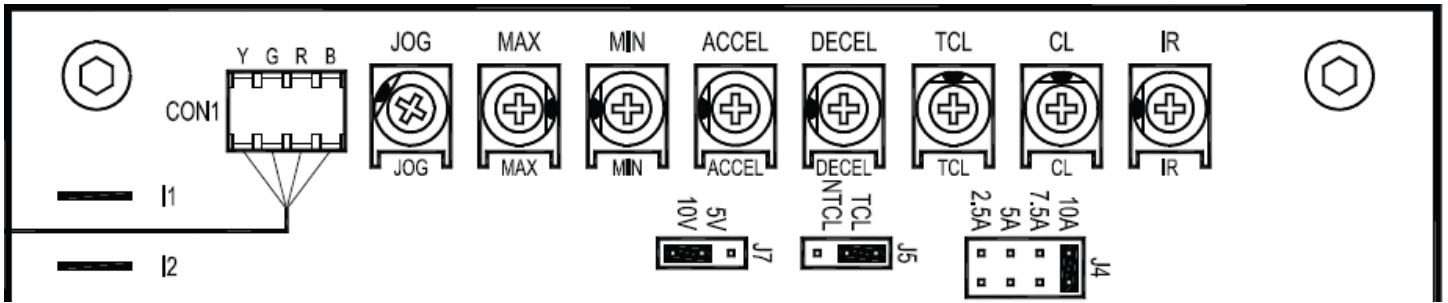

Inside of the KB control you will see a set of potentiometers at the top of the control. These trim pots are used to adjust the following parameters jog, max, min, acceleration and deceleration. TCL, CL and IR are preset and should not be adjusted please call the PA service department if you need to adjust these pots. The min and max trim pots set the minimum and maximum speed of the motor. If you set the max too high then you will receive a red CL indicator light (See Troubleshooting). If you receive a red CL light, simply dial the trim pot back until you no longer get the red light.

NOTE: Do not adjust trimpots with main power on.

4 Maintenance

4.1 Mechanical

Mandrel

SEQ.	MAINT. ITEM	REQUIREMENT	FREQUENCY-DAYS
1	Jaw Linkage	Apply (SAE30) Lube Oil	14
2	Main Shaft Bearing	Apply Standard Grease to Fittings	14

Gear Reducer

The reducer requires no periodic maintenance. However, an occasional visual inspection to check for hardware tightness, leakage and the general overall condition of the reducer is good practice. This reducer is designed to operate successfully without breather vents. Since the reducer is shipped with lubricant, and breather plugs are not required, the user is able to eliminate the lengthy preparation normally required to place a reducer into service.

Drive Chain and Maintenance

SEQ.	MAINT. ITEM	REQUIREMENT	FREQUENCY-DAYS
1	Check Chain Tension	Adjust as Necessary	30
2	Lubricate Chain	Apply Chain Grease	30

At approximately 90 day intervals, or if proper torque is not being maintained, inspect Torque Limiter for presence of oil, grease, moisture or corrosion on driving surfaces and for proper setting of spring load. Clean and adjust as required. Friction facings and bushings are the only parts that should normally require replacement.

5 Specifications

5.1 Overall Model Specifications

Model	Max Coil Weight lbs(Kg)	Max Stock Width in(mm)	ID Range in(mm)	Max OD Range in(mm)	Jaw Quantity	Speed Range (RPM)	Drive Motor HP(kW)	AC Power Input V/Ph/Hz
		W/ keepers	Wout/ Keepers	12-20.5(300-520)	51-60(1.3-1.52)			
SRA1612	1600(727)	12(305)	15(381)	15.7-20.5(400-520)	55-60(1.4-1.53)	4	4-23	3/4(0.56) 120/1/60
SRA2516	2500(1136)	16(400)	20(500)	15.7-20.5(400-520)	55-60(1.4-1.53)	4	3-15	3/4(0.56) 120/1/60
SRA4524	4500(2045)	24(610)	28(711)	15.7-20.5(400-520)	55-60(1.4-1.53)	4	3-15	1(0.75) 230/1/60
SRA6512	6500(3000)	12(305)	16(406)	15.7-20.5(400-520)	55-60(1.4-1.53)	3	3-15	2(1.50) 230/3/60
SRA6524	6500(3000)	24(610)	28(711)	15.7-20.5(400-520)	55-60(1.4-1.53)	3	3-15	2(1.50) 230/3/60
SRA6536	6500(3000)	36(915)	40(1016)	15.7-20.5(400-520)	55-60(1.4-1.53)	3	3-15	2(1.50) 230/3/60

5.2 Parts List

Item#	1612 Part#	2516 Part#	4524 Part#	6512 Part#	6524 Part#	6536 Part#	Description	Qty
1	N/A	N/A	N/A	G-STW100	G-STW100	G-STW100	Shaft Retaining Ring	1
2	N/A	N/A	N/A	F-NSK6220ZZ	F-NSK6220ZZ	F-NSK6220ZZ	Rear Bearing	1
3	N/A	N/A	N/A	G-AN23	G-AN23	G-AN23	Locknut	2
4	N/A	N/A	N/A	U303-1109	U303-1109	U303-1109	Sprocket and disc, brake	1
5	N/A	N/A	N/A	U303-0610	U303-0610	U303-0610	Bushing	1
6	MU30-1209	MU30-1209	MU30-1209	U505-0709	U505-0709	U505-0709	Fixing Wheel	16/12
7	MU30-12125	MU30-12121	MU30-12121	U503-12051	U503-12051	U503-12051	Keepers	6
8	MU30-12141	MU30-12141	MU30-12141	G-C1640	G-C1640	G-C1640	Hand Lever	6
9	N/A	N/A	N/A	U505-0707	U505-0707	U505-0707	Linkage Pin	18
10	MU30-1202	MU40-1202	MU50-12021	U303-0710	U303-0710	U303-0710	Spacer	1
11	F-NSK51105	12117-114	12117-114	F-NSK51310	F-NSK51310	F-NSK51310	Thrust Ball Bearing	1
12	MU30-1104	MU40-1104	MU40-1104	MU50-1104	MU50-1104	MU50-1104	Expansion Screw	1
13	F-NSK6205ZZ	F-NSK6206ZZ	F-NSK6205ZZ	F-NSK6208ZZ	F-NSK6208ZZ	F-NSK6208ZZ	Expansion Screw Bearing	1
14	G-ZL242-1	G-ZL242-1	G-ZL242-1	G-ZL242-1	G-ZL242-1	G-ZL242-1	Handle	1

Item#	1612 Part#	2516 Part#	4524 Part#	6512 Part#	6524 Part#	6536 Part#	Description	Qty
15	MU30-12111	MU30-12111	MU30-12111	MU30-1211	MU30-1211	MU30-1211	Crank Handle	1
16	DIN-912- M8X80	DIN-912- M8X100	DIN-912- M8X100	DIN-912- M12X110	DIN-912- M12X110	DIN-912- M12X110	M12 Socket Head Cap Screw	6
17	MU30-1203	MU40-1203	MU50-12031	U303-0711	U303-0711	U303-0711	Bearing Holder	1
18	N/A	N/A	N/A	G-AW23	G-AW23	G-AW23	Lockwasher	2
19	N/A	N/A	N/A	U303-1106	U303-1106	U303-1106	Front Bearing Holder	1
20	F-NSK6205ZZ	N/A	N/A	F-NSK6224ZZ	F-NSK6224ZZ	F-NSK6224ZZ	Front Bearing	1
21	N/A	N/A	N/A	U303-1107	U303-1107	U303-1107	Bearing Holder	1
22	MU30-11052	MU40-1105	MU50-1105	U303-0702	U303-0702	U303-0702	Inner Keeper	1
23	MU30-1201	MU40-1201	MU50-1201	A (U303-0701)	A (U503-0701)	A (U903-0701)	Expansion Slide	1
24	MU30-12125	MU30-1205	MU50-1205	B (U303-1203)	B (U503-07031)	B (U903-0703)	Jaw Bracket	3
25	MU40-12101	MU40-12101	MU60-12101	C (U303-1204)	C (U605-1204)	C (905-0702)	Expansion Jaw	3
26	MU30-12064	MU30-12062	MU30-1206	E (U505-0704)	E (U505-07041)	E (U905-0704)	Connecting Link	12
27	MU30-1103	MU40-1103	MU50-11031	F (U303-0604)	F (U503-0604)	F (U903-0604)	Main Shaft	1
28	G-STW20	G-STW20	G-STW20	G-STW20	G-STW20	G-STW20	Pin Retaining Ring	36
29	MU30-12042	MU30-1204	MU50-1204	N/A	N/A	N/A	Mandrel Tie Bar	4
30	MU30-1207	MU30-1207	MU30-1207	N/A	N/A	N/A	Linkage Pin	16
31	MU30-1208	MU30-1208	MU30-1208	N/A	N/A	N/A	Keeper Disc Pin	8
32	12133-41	UCF215	UCF218	N/A	N/A	N/A	Pillow Block Bearing	2
33	A	A	A	M	M	M	Cabinet	1
34	G	G	G	O	O	O	Motor	1
35	H	H	H	P	P	P	Chain	1
36	I	I	I	N/A	N/A	N/A	Upper Sprocket	1
37	E	E	E	Q	Q	Q	Lower Sprocket	1
38	B	B	B	N	N	N	Control Assembly	1
39	D	D	D	T	T	T	WormGear Reducer	1
40	F	F	F	N/A	N/A	N/A	Helical Reducer	1
41	K	K	K	N/A	N/A	N/A	Brake Disc	1
42	J	J	J	U	U	U	Pneumatic Brake Cylinder	1
43	L	L	L	V	V	V	Brake Cylinder Bracket	1
44	N/A	N/A	N/A	R	R	R	Torque Limiter	1
45	C	C	C	S	S	S	WormGear Bracket	1/2

5.3 Overall Dimensions & Drawings

Models 1612 to 4524

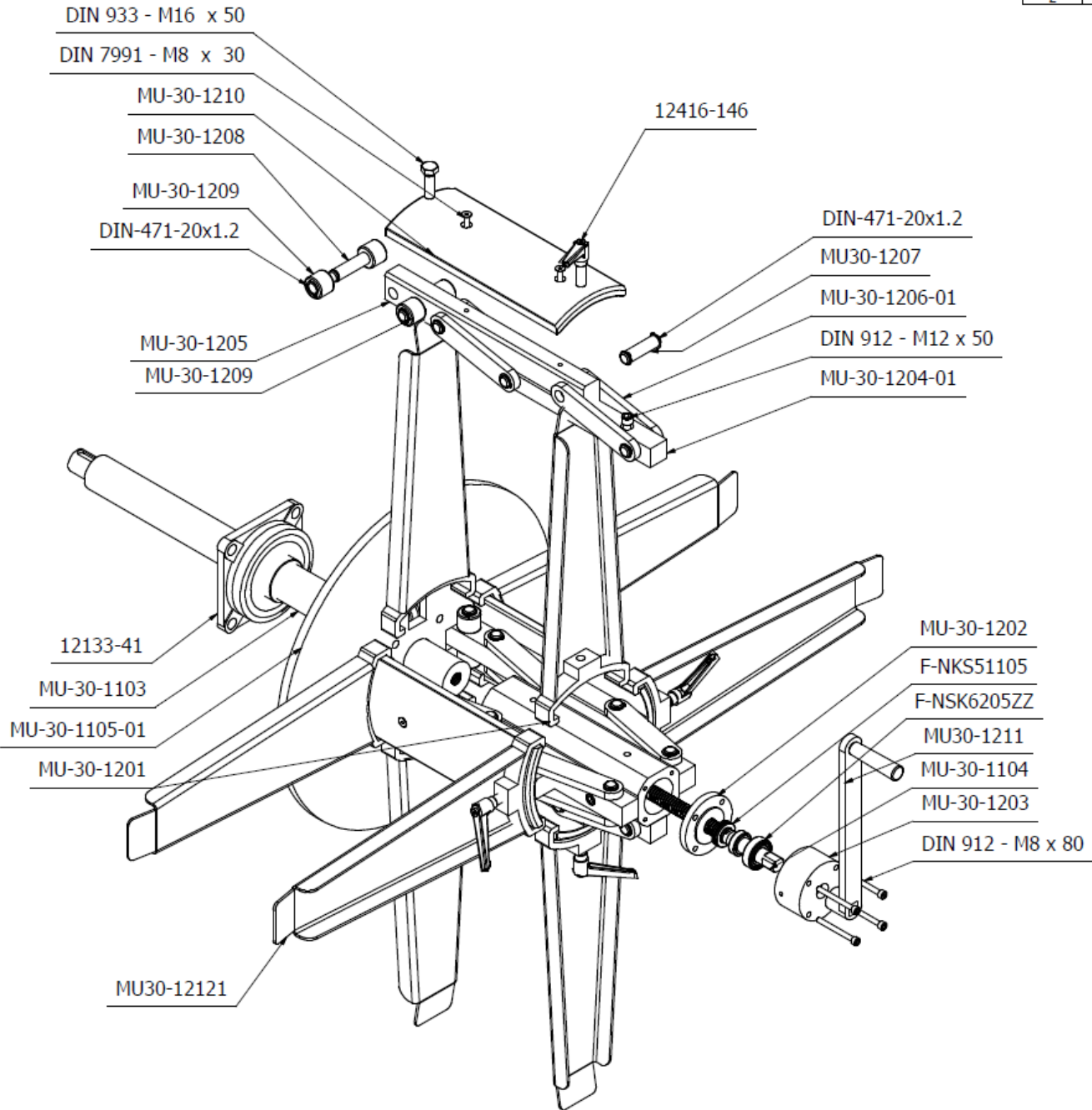

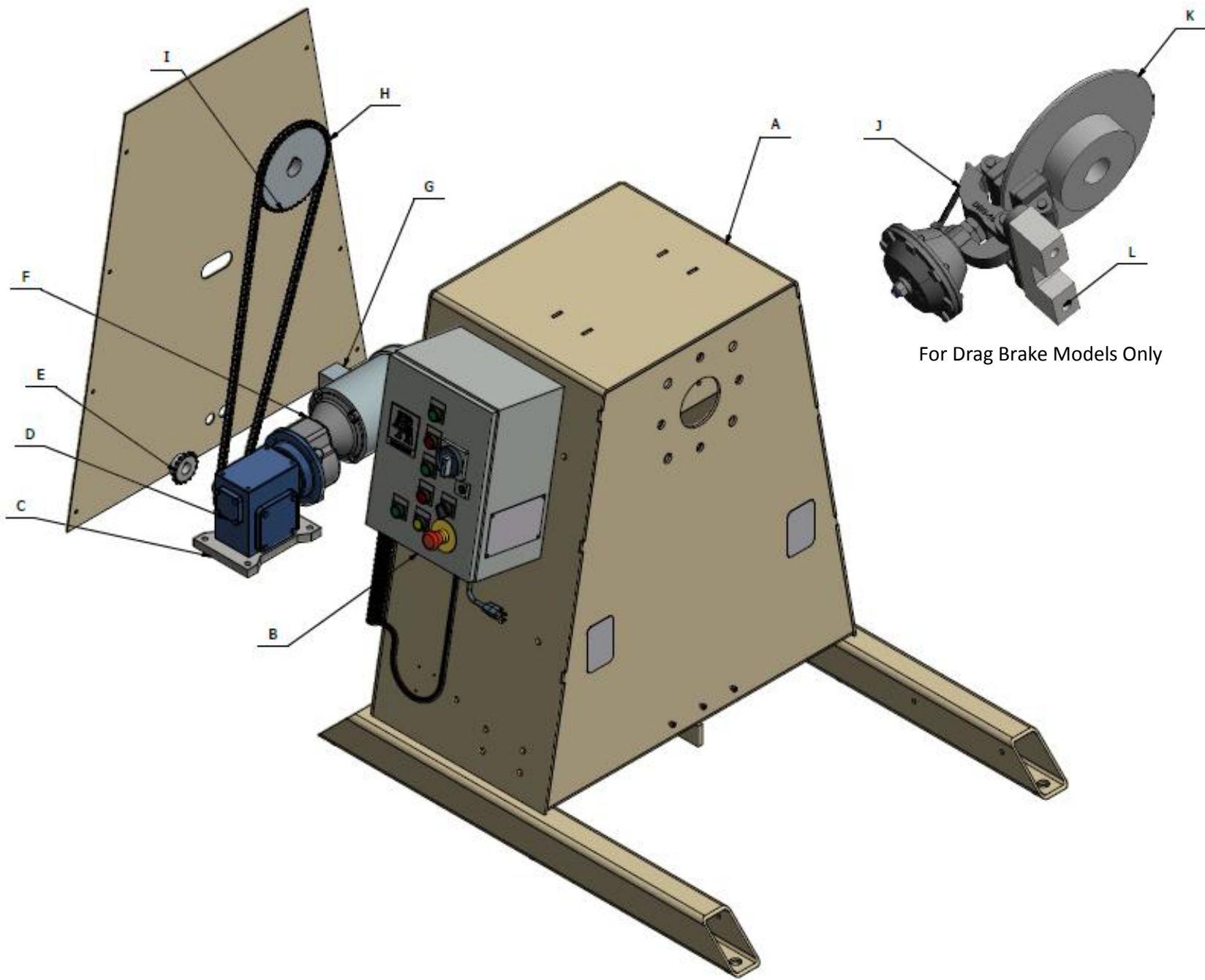

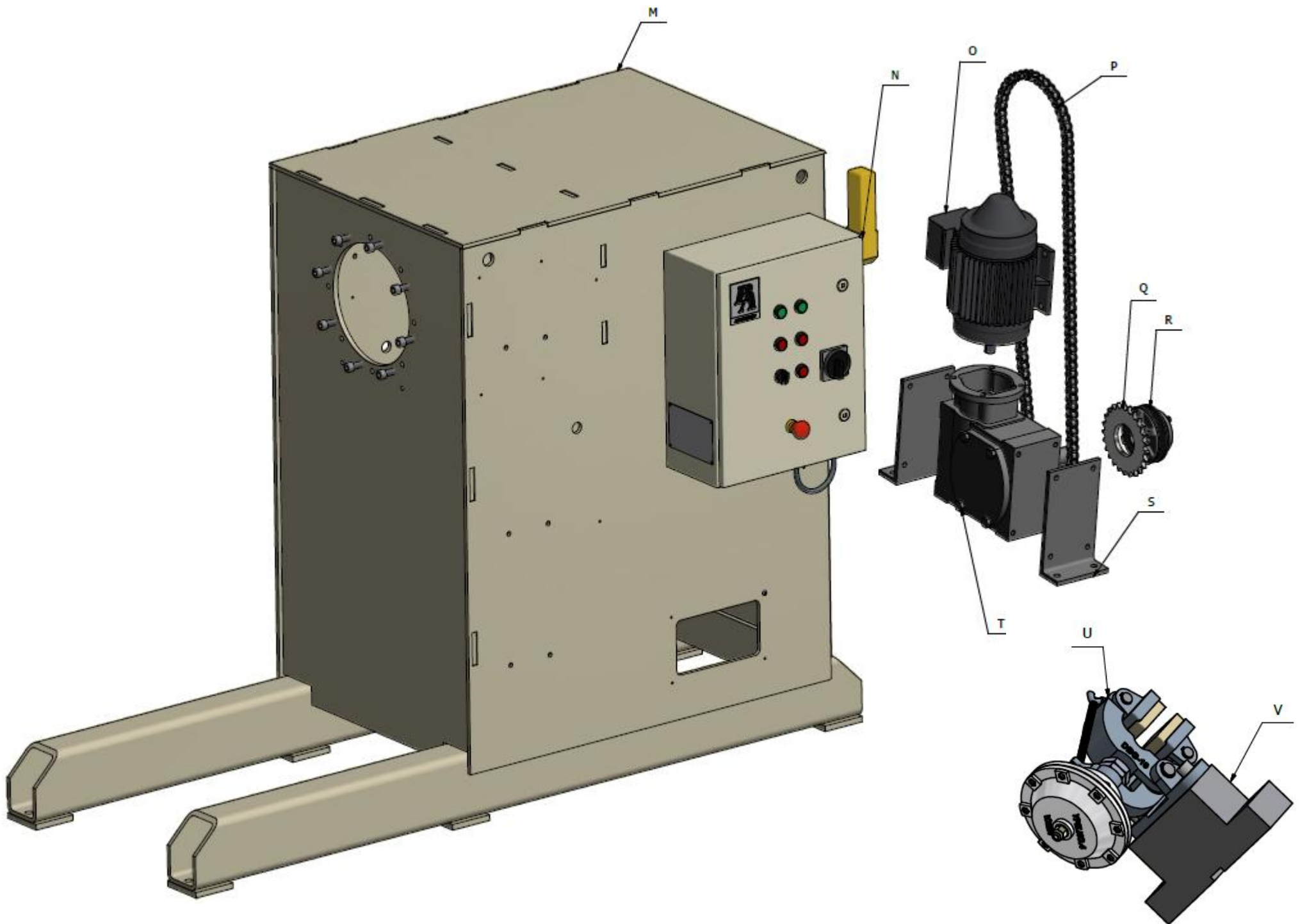

5.4 VFD Status / Warning Messages

Status / Warning	Cause	Solution
bF Drive ID Warning	The Drive ID (P502) stored on the EPM does not match the drive model	Verify motor data (P302-306) and perform Auto Calibration, Set drive mode (P300) to 0 or 1, Reset the drive (P199 to 3 or 4) and reprogram
CAL Motor Auto Calibration	Refer to P300, 399	Motor Auto-Calibration is being performed
cE An EPM that contains valid data from a previous software version has been installed	An attempt was made to change parameter settings	Parameter settings can only be changed after the EPM data is converted to the current version (P199 = 5)
CL Current Limit (P171) reached	Motor Overload	Increase P171, Verify drive/motor are proper size for application
dEC Decel Override	The drive has stopped decelerating to avoid tripping into HF fault, due to excessive motor regen (2 seconds max)	If the drive trips to HF fault: Increase P105, P126, Install Dynamic Braking option
Err Error	Invalid data was entered, or an invalid command was attempted	
FCL Fast Current Limit	Overload	Verify drive/motor are proper size for application
GE OEM Settings Operation Warning	An attempt was made to change parameter settings while the drive is operating in OEM settings mode	In OEM Settings mode (P199 = 1), making changes to parameters is not permitted
GF OEM Defaults Data Warning	An attempt was made to use (or reset to) the OEM default settings (P199 = 1 or 2) using an EPM without valid OEM data	Install EPM containing valid OEM Defaults data
LC Fault Lockout	The drive attempted 5 starts after a fault but all attempts were unsuccessful (P110 = 3-6)	Drive requires manual reset, Check fault history (P500) and correct the fault condition
F_AF High Temperature fault	Drive is too hot inside	Reduce drive load, Improve cooling
F_AL Assertion Level fault	Assertion Level switch is changed during operation, P120 is changed during operation, P100 or P121-P124 are set to a value other than 0 and P120 does not match the Assertion Level switch	Make sure the Assertion Level switch and P120 are both set for the type of input devices being used prior to setting P100 or P121-P124. Refer to 3.2.3 and P120
F_bF Personality fault	Drive Hardware	Cycle Power, Power down and install EPM with valid data, Reset the drive back to defaults (P199 = 3 or 4) and then re-program, If the problem persists, contact factory technical support
F_CF Control fault	An EPM has been installed that is either blank or corrupted	
F_cF Incompatible EPM fault	An EPM has been installed that contains data from an incompatible parameter version	

F_cFt	Forced Translation fault	An EPM from an old drive put into a new drive	Press [M] (mode button) twice to reset
F_dbF	Dynamic Braking fault	Dynamic braking resistors are overheating	Increase active decel time (P105, P126, P127), Check main voltage and P107
F_EF	External fault	P121-P124 = 21 and that digital input has been opened, P121-P124 = 22 and that digital input has been closed	Correct the external fault condition, Make sure digital input is set properly for NC or NO circuit
F_F1	EPM fault	EPM missing or defective	Power down and replace EPM
F_Fnr	Control Configuration fault	The drive is setup for REMOTE KEYPAD control (P100 = 2 or 5) but is not set up for network communication	Set P400 = 1 or P600 = 1
		4-20mA signal (at TB-25) drops below the value set in P164	Set P400 or P600 to a valid network communications protocol selection
F_GF	OEM Defaults data fault	Drive is powered up with P199 = 1 and OEM settings in the EPM are not valid	Install an EPM containing valid OEM defaults data or change P199 to 0
F_HF	High DC Bus Voltage fault	Mains voltage is too high	Check main voltage and P107
		Decel time is too short, or too much regen from the motor	Increase decel time (P105, P126, P127) or install Dynamic Braking option
F_IL	Digital Input Configuration fault (P121-P124)	More than one digital input set for the same function	Each setting can only be used once (except setting 0 and 3)
		Only one digital input configured for MOP function (up, Down)	One input must be set to MOP up, another must be set to MOP down
		PID mode is entered with set point reference and feedback source set to the same analog signal	Change PID set point reference (P121-P124 or feedback source (P201)
		One of the digital inputs (P121-P124) is set to 10 and another is set to 11-14	Reconfigure digital inputs
		One of the digital inputs (P121-P124) is set to 11 or 12 and another is set to 13-14	
		PID enabled in Vector Torque mode (P200 = 1 or 2 and P300 = 5)	PID cannot be used in Vector Torque mode
F_LF	Low DC Bus Voltage fault	Main voltage is too low	Check main voltage
F_nId	No Motor ID fault	An attempt was made to start the drive in Vector or Enhanced V/Hz mode prior to performing the Motor Auto-Calibration	Refer to parameters P300-P399 for Drive Mode setup and calibration
F_OF	Output fault: Transistor fault	Output short circuit	Check motor/motor cable
		Acceleration time too short	Increase P104, P125
		Severe motor overload due to: Mechanical problem, Drive/motor too small for application	Check machine/system, Verify drive/motor are proper size for application
		Boost values too high	Decrease P168, P169

		Excessive capacitive charging current of the motor cable	Use shorter motor cables with lower charging current, Use low capacitance motor cables, Install reactor between motor and drive
		Failed output transistor	Contact factory for technical support
F_OF1	Output fault: Ground fault	Grounded motor phase	Check motor cable
		Excessive capacitive charging current of the motor cable	Use shorter motor cables with lower charging current
F_PF	Motor Overload fault	Excessive motor load for too long	Verify proper setting of P108, Verify drive and motor are proper size for application
F_rF	Flying Restart fault	Controller was unable to synchronize with the motor during restart attempt; (P110 = 5 or 6)	Check motor/load
F_SF	Single-Phase fault	A line phase has been lost	Check line phases / voltage
F_UF	Start fault	Start command was present when power was applied (P110 = 0 or 2)	Must wait at least 2 seconds after power-up to apply Start command, Consider alternate starting method (P110)
F_FAU	TB5 (0-10V signal) Threshold fault	0-10V signal (at TB5) drops below the value set in P158	Check signal/signal wire, Refer to parameter P157 and P158