



P/A INDUSTRIES INC., 522 Cottage Grove Road, Bloomfield, CT 06002-3191 USA



www.pa.com

TRANSPORTER

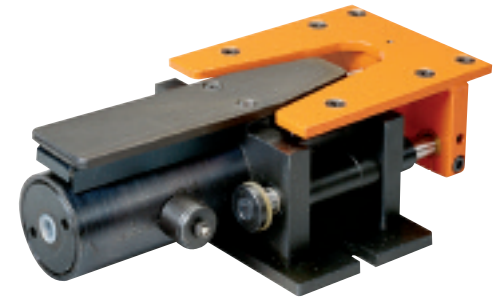
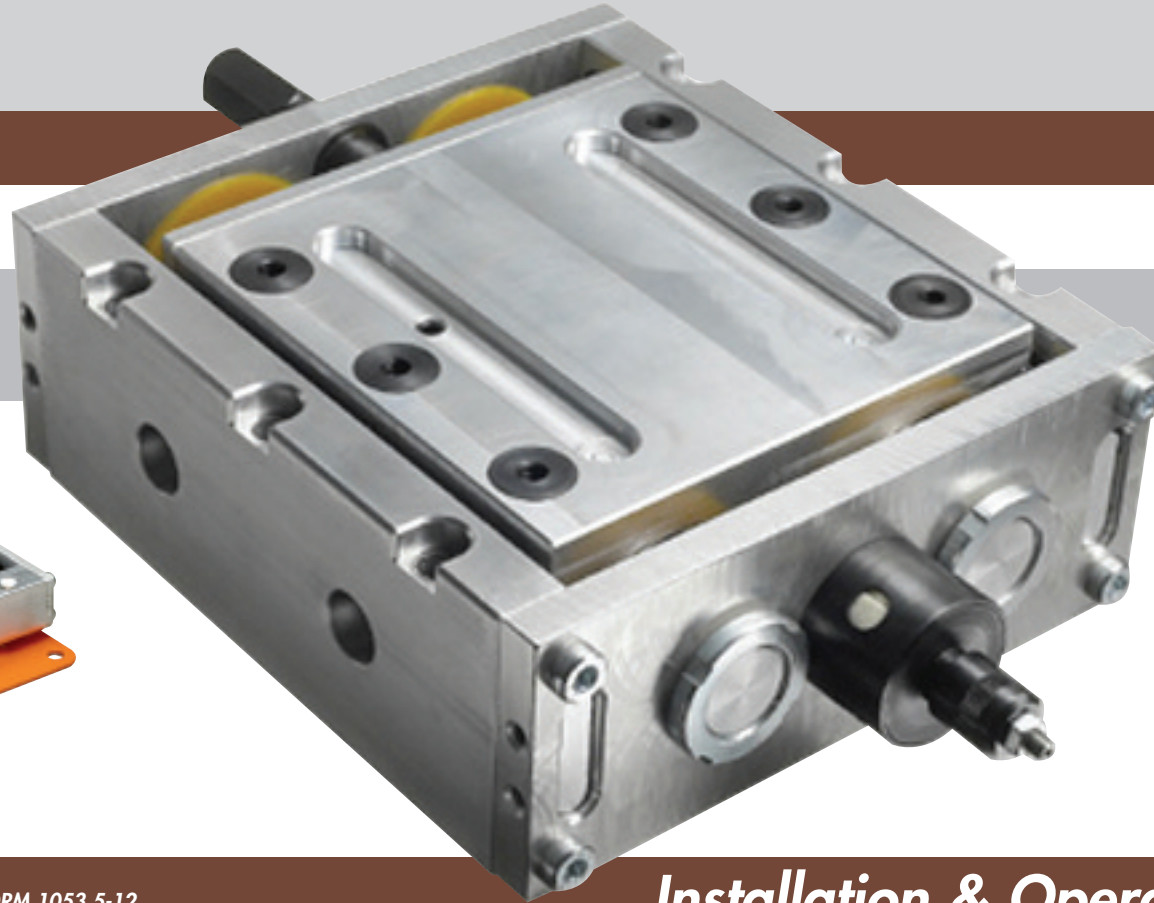
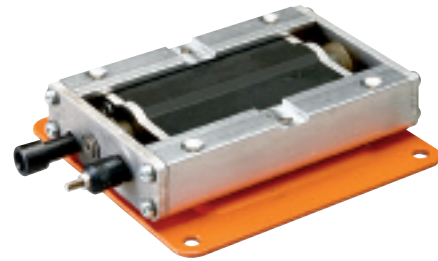
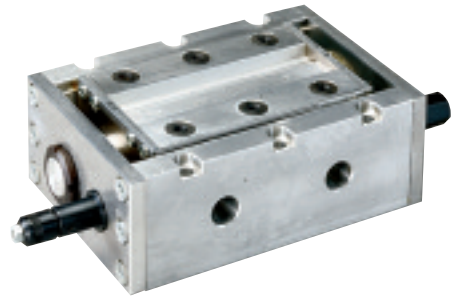

Toll-Free: 1-800-243-8306, Worldwide: 1-860-243-8306, Fax: 1-860-242-4870, E-mail: sales@pa.com FORM 1053 5-12

Installation & Operating Instruction Manual

P/A INDUSTRIES INC.

The Original Transporter.

The Transporter is a totally unique material handling device. Protected under USA and foreign patents, these low profile, beltless conveyors are pneumatically powered and have become a cost effective alternative to conventional conveyors. There are no belts or bearings to wear out or maintain.

The rhythmic vibrating or shaking motion moves parts or scrap along a custom tray or chute designed to fit your tool or application. Trays can be fabricated out of various materials to suit any size opening and transport the pieces into the parts bin or scrap container.

Contact our Sales Application Engineering Department for a free video showing several different ways customers have used the Transporter.

APPLICATIONS 3

INSTALLATION 4

MODEL TP-3 SERVICE 6

MODEL TP-10 SERVICE 10

MODEL TP-40 SERVICE 14

MODEL TP-70 SERVICE 18

MODEL TP-140 SERVICE 22

TECHNICAL DATA 26

RECOMMENDED TRAY SUPPORTS 27

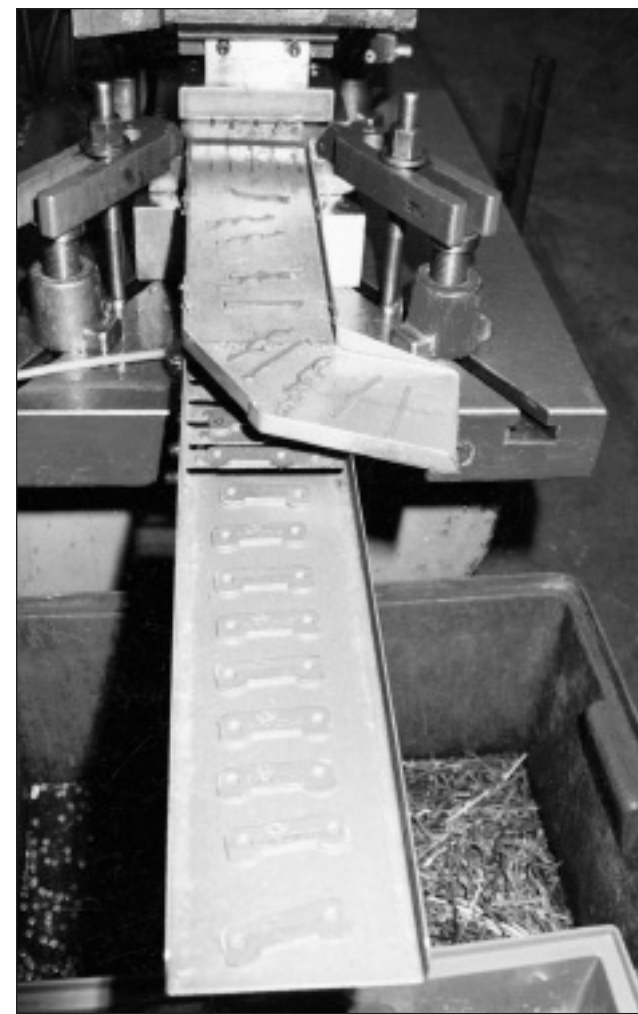

APPLICATIONS

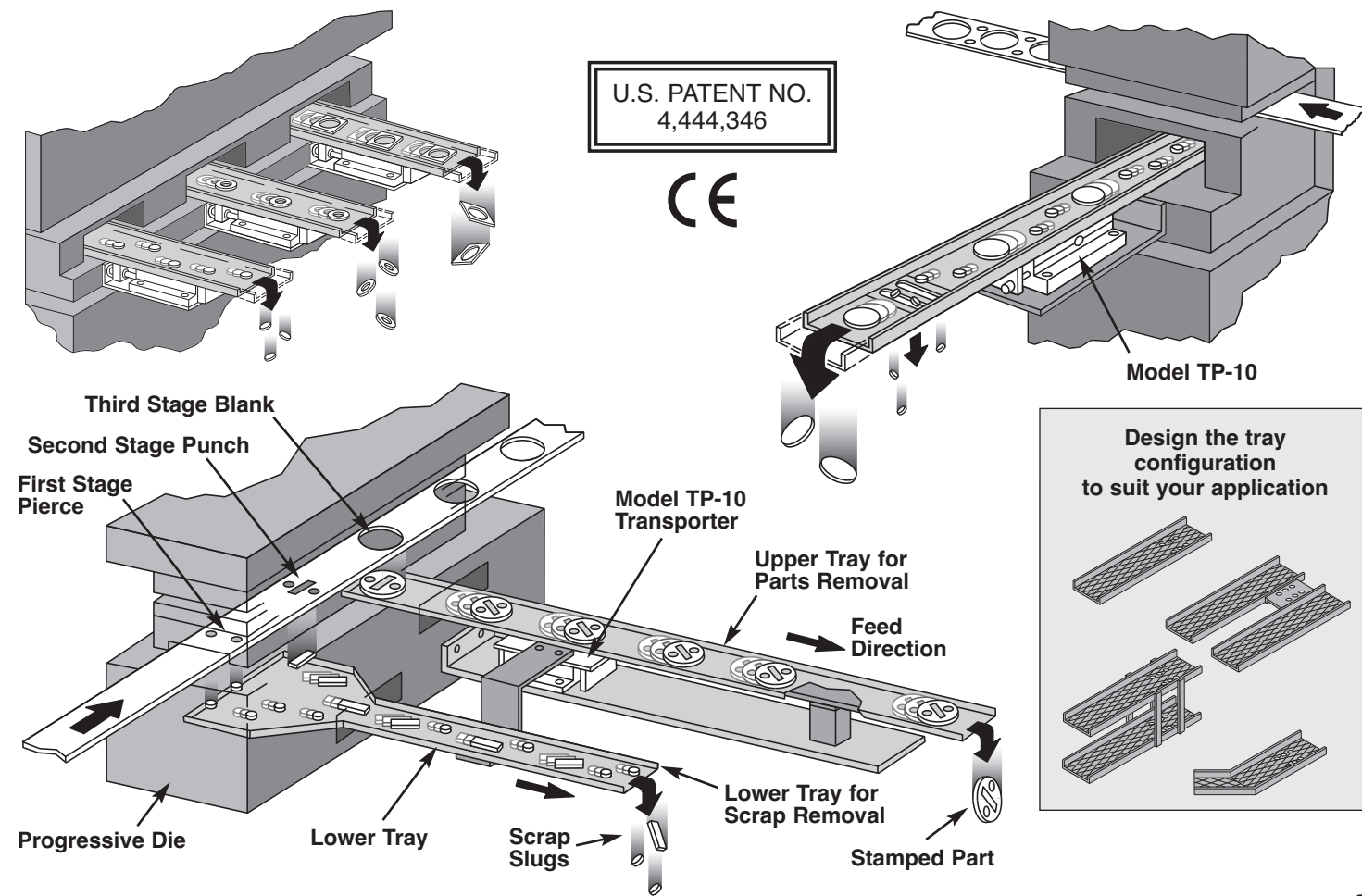

INSTALLATION

1. Rigidly Mount the Transporter to a solid surface using these recommended bolts sizes:

Model	Quantity	Metric	Inch
TP-3	4	M 8	5/16
TP-10	4	M 8	5/16
TP-40	2	M10	3/8
TP-70	6	M 8	5/16
TP-140	6	M 8	5/16

2. Air line requires use of an oil mist-type combination Filter/Regulator/Lubricator, and Pressure Gauge. Set pressure to 4-5 Bar (60 to 75 psi). Do not exceed 5.5 Bar (80 psi) as excess pressure will damage the Transporter.

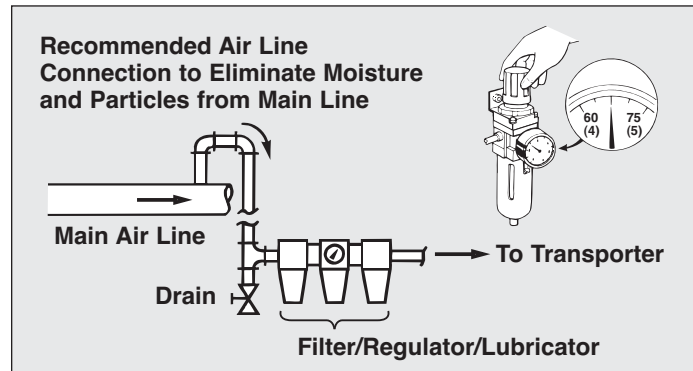

3. Fill the Lubricator with a good grade of hydraulic oil such as Shell Tellus 32 or equivalent. Set the Lubricator for one (1) drop per minute.

4. Connect the Air Line with flexible poly-flow tubing into the threaded inlet. On Model TP-3 use 1/4" tubing for 1/8" NPT. Models TP-10, TP-40, TP-70 and TP-140 use 3/8" tubing for 1/4" NPT.

5. A custom "U" profile tray or chute must be designed to handle each specific application or tool. Any material can be used, but we recommend aluminum or any light gauge material to reduce tray weight. Maximum tray weight should not exceed the following table data:

Tray & Scrap Model	Max. Weight Tray Only		Max. Weight of Parts	
	Kg	Lbs.	Kg	Lbs.
TP-3	1,5	3.3	3	6.6
TP-10	3	6.6	10	20
TP-40	15	33	40	80
TP-70	50	110	70	140
TP-140	100	200	140	300

6. Fasten the tray or chute to the Transporter with metric screws at **all holes**. Be sure to use spacers or washers between the Transporter and the tray to reduce contact friction between the moving tray and the Transporter body. Refer to the following table.

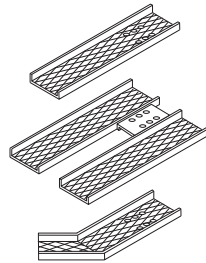

INSTALLATION

Model	Quantity	Screw size	Depth
TP-3	6	M6	8mm
TP-10	6	M6	8mm
TP-40	6	M8	9mm
TP-70	6	M8	8mm
TP-140	6	M8	8mm

7. The Conveyor tray or chute must be supported at both ends to minimize vibration and deflection. A block of Delrin GP-500 or Nylon, low friction material can be used for the tray to slide. For optimum installation, use P/A Roller Slides to rigidly control the tray movement and provide trouble-free operation. See page 27.

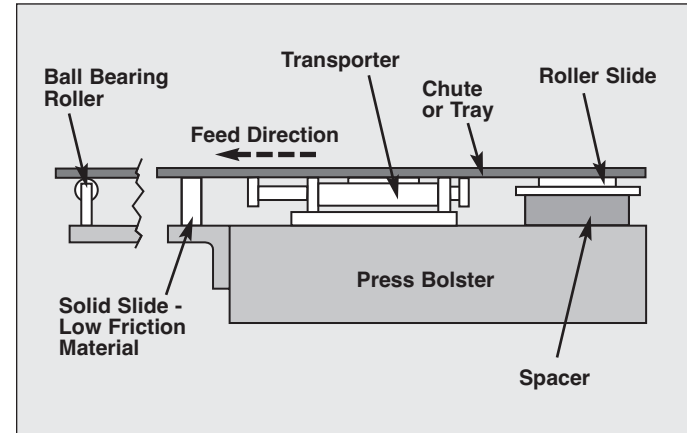

8. The Speed Adjustment is preset at the factory with the correct frequency for a light weight tray or chute. The speed can be adjusted by turning the screw or knob clockwise to decrease the movement on the Models TP-3, TP-10, and TP-40. The TP-70 and TP-140 are adjusted by turning the screw or knob counter-clockwise to decrease the movement. Maximum speed is not required to move parts or scrap efficiently.

9. If the TP-40 Speed Frequency is inadequate, release the Air Regulator Rod T40-029 and gently push forward to increase speed or backward to decrease.

10. The TP-10 may require a slight adjustment to maintain proper speed frequency after a period of operation. If Speed Adjustment Screw T10-405 does not slow the unit sufficiently, it may be necessary to slightly snug the two screws at the Air Regulator Valve T10-401. This reduces the air being released from the valve and decreases speed. Snugging the screws too tightly will cause bending of the Air Regulator Rod and poor performance.

11. Spray the same Tellus oil used in lubrication on the pistons each week.

12. If there is a build-up of sticky oil on the conveyor tray or if the parts or scrap are very oily, they may stick to the surface and reduce movement. To reduce the coefficient of friction, try dimpling the surface of the conveyor chute with a ballpeen hammer or use a different material like expanded metal or profiled, roll formed material.

MODEL TP-3 SERVICE



Factory Repair & Rebuild Service

Return the Transporter by UPS **Prepaid** to our repair center. After teardown and inspection, P/A Industries will notify you of the recommended cost for spare parts and labor.

Disassembly

1. Remove both Snap Rings and push the Front and Rear Pistons inside Body.
2. Remove the Screws from the Rear Guide Holder T3-204. Pull out together with Speed Adjustment Knob T3-401.
3. Remove the Front Guide Holder T3-203.
4. Remove both Guide Holders (L & R) T3-201 and the twelve (12) Ball Bearings.
5. Back out the Locking Screw T3-406 and remove the Speed Adjustment Valve T3-603.
6. With both T3-701 Tools provided in the kit, remove the Valve Discs and the Rod.
7. Check all "O" Rings, Springs, Discs, and Seals for damage and replace as needed.

Reassembly

1. Install the Speed Adjustment Valve T3-603 and align with the groove for the Locking Screw T3-406.
2. Insert the Front Piston T3-302 into the Body with the Bumper Ring.
3. Mount the Bumper Ring and insert the Rear Piston T3-303 into the Body.
4. Grease both Guide Holders T3-201 and put twelve (12) Ball Bearings into both Bearing Plates T3-210. Hold the Bearing Plates by hand while attaching Front and Rear Holders. **The Guide Holder assembly must run smoothly in both directions without side-to-side play.**
5. Pull both Pistons T3-302 and T3-303 back into position and secure the Snap Rings.

MODEL TP-3 DIMENSIONAL DRAWING

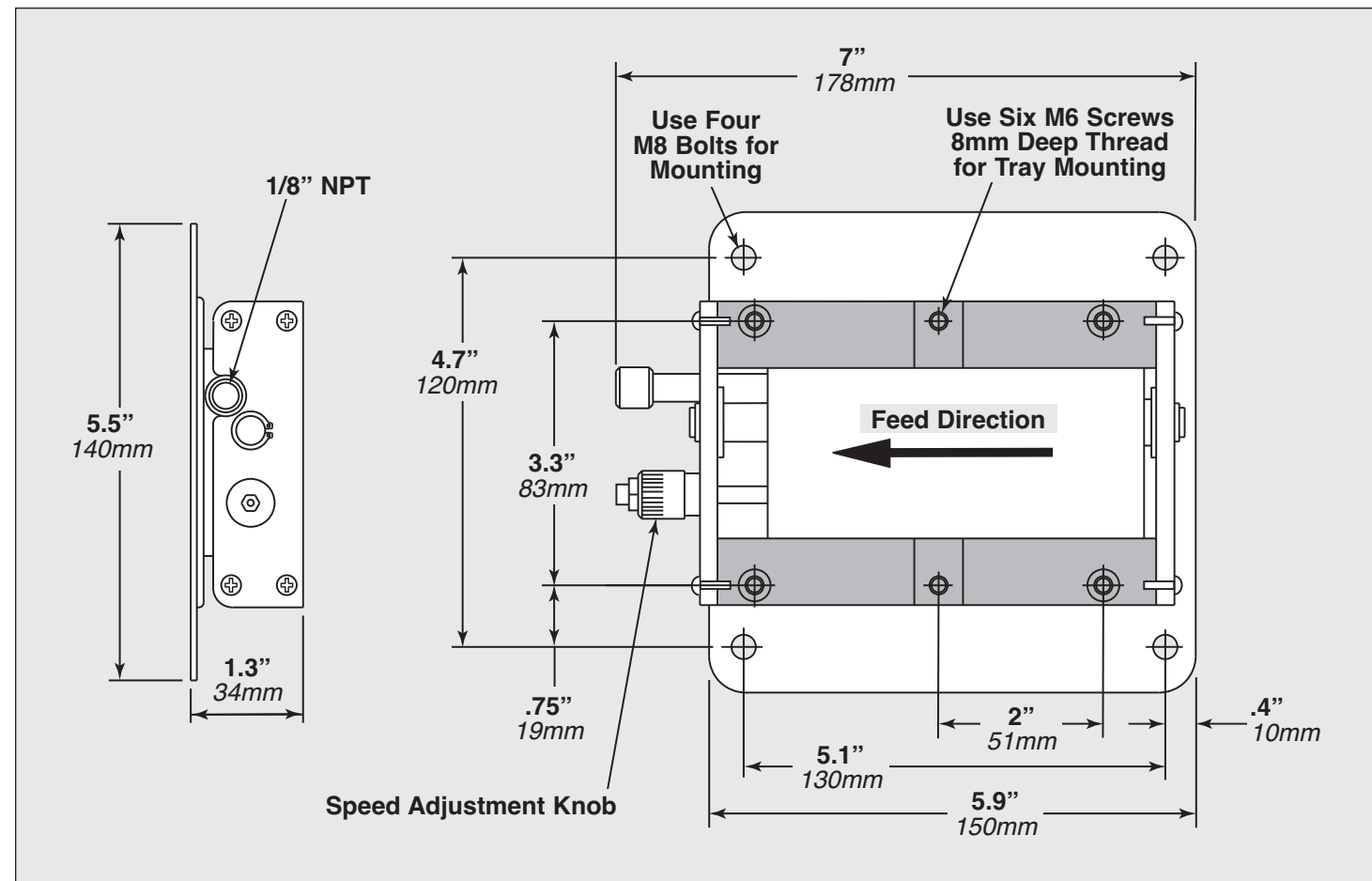

TP-3 Parts Description

Part No.	Description	Qty
T3-105	Screw	8
T3-107	Air inlet	1
T3-110	Mounting plate	1
T3-111	Mounting plate screw	4
T3-112	Spring pin	4
T3-201	Guide holder (L&R)	2
T3-203	Front guide holder	1
T3-204	Rear guide holder	1
T3-210	Sleeve retainer	2
T3-211	Stainless Steel Ball	12
T3-302	Front piston	1
T3-303	Rear piston	1
* T3-307	Grease O-ring	1
T3-308	Grease ring	1
* T3-311	Valve seal	2
* T3-322	Rear cup seal	1
* T3-323	Front cup seal	1
* T3-327	Bumper ring	2
T3-401	Speed adjustment knob	1
T3-402	Speed adjustment rod	1
T3-404	Threaded bushing	1
T3-405	Plug	1
T3-406	Locking screw	1
* T3-407	Speed valve O-ring	2
T3-309	Knob locking nut	1
* T3-412	Speed valve O-ring	1
T3-601	Valverod assembly	1
T3-602	Spring assembly	2
T3-603	Valve assembly	1
* T3-701	Assembly tool	2
T10-209	Snap ring	2
T10-313	Spring	1
* T70-306	Knob O-ring (*14208-011)	1

* Included in Repair Kit 3-001 (17269)

TP-3 Assemblies

T3-601	Valve Rod Assembly	Qty
T3-310	Valve rod	1
T3-325	O-ring	1

T3-602	Spring Assembly	Qty
T3-315	Spring holder	1
T3-407	O-ring	1
T10-313	Spring	1

T3-603	Valve Assembly	Qty
T3-402	Speed adjustment knob	1
T3-407	O-ring	1
T3-411	Valve	1
T3-412	O-ring	1

TP-3 PARTS DRAWING

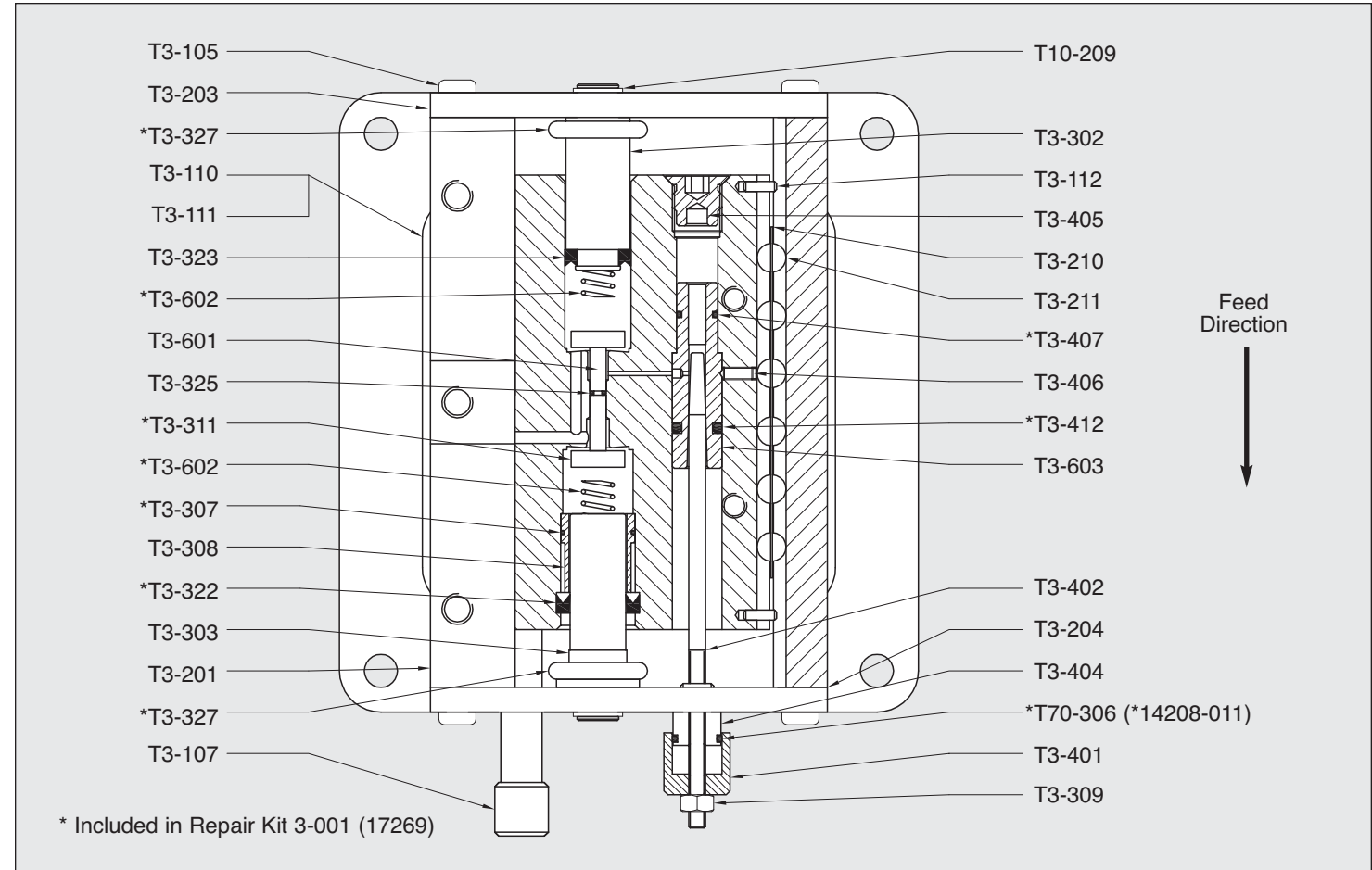

MODEL TP-10 SERVICE

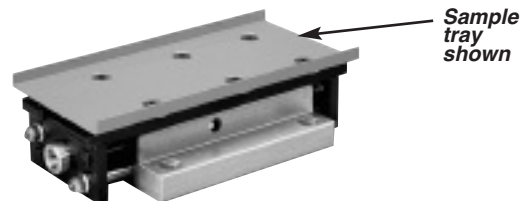

Factory Repair & Rebuild Service

Return the Transporter by UPS **Prepaid** to our repair center. After teardown and inspection, P/A Industries will notify you of the recommended cost for spare parts and labor.

Disassembly

1. Remove the Guide Column Locking Nuts T10-214 and the Tray Holder Screws T10-210 for the Front Holder T10-202.
2. Pull out the Front Holder T10-202 together with the Air Regulator Rod and Nut T10-604 and Threaded Guide Columns T10-203.
3. Pull out the Rear Holder T10-201 together with the Rear Pistons T10-303.
4. Remove the Air Inlet T10-601 and O-Ring 14208-119 with an 8 mm hex wrench.
5. Remove the Nut T10-305 from the Piston T10-302.
6. Remove the disc from the Valve Rod using a Phillips head screwdriver at the T10-325, and a 13 mm socket at the opposite end.
7. Remove the Piston Valve Assembly T10-606.

8. Carefully Disassemble the Piston Valve Assembly.
9. Examine all Springs, "O" Rings, and Valve Discs for damage and replace as necessary.

Reassembly

1. Verify that the Extension, Inner Disc, and Valve Rod must be very straight and not overtightened.
2. Assemble all components of the Piston Valve Assembly T10-606, install in the Transporter Body, and add the Outer Disc, noting the .015" (.38mm) movement for proper operation.
3. If many parts have been replaced, the Transporter may need a brief run-in period before final adjustments are made.

MODEL TP-10 DIMENSIONAL DRAWING

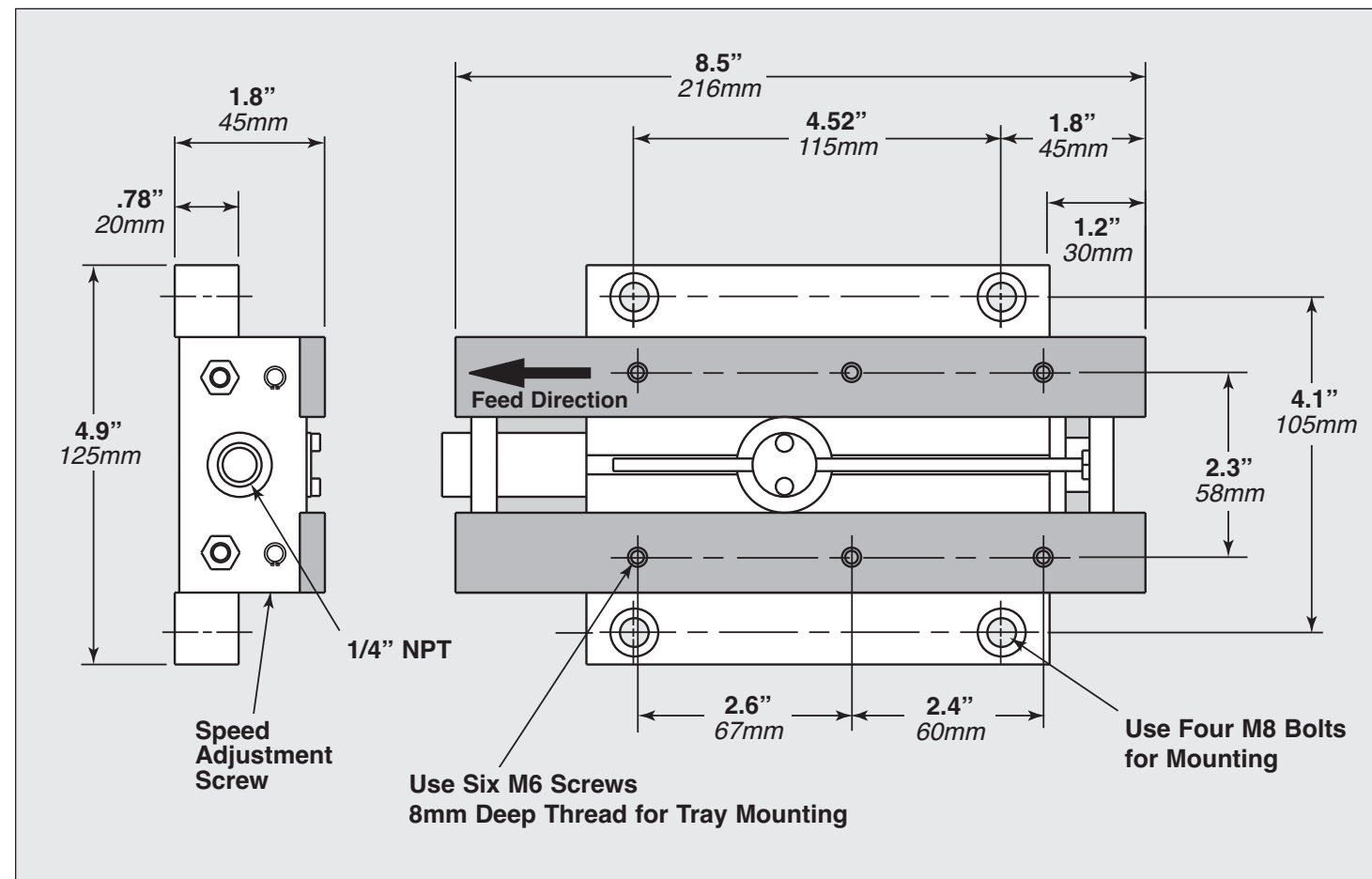

TP-10 Parts Description

Part No.	Description	Qty
* T10-106	Guide column sleeve	4
T10-201	Rear holder	1
T10-202	Front holder	1
T10-203	Threaded guide column	2
T10-204	Tray holder set (L & R)	2
T10-209	Snap ring	2
T10-210	Tray holder screw	4
* T10-212	Urethane washer	4
T10-213	Guide column spacer	2
T10-214	Guide column locking nut	4
T10-302	Piston	1
T10-303	Rear piston	2
T10-305	Nut, piston	1
T10-311	Valve disk	2
T10-313	Spring, long	1
T10-314	Spring, short	1
* T10-316	Gasket	1
T10-318	Valve O-ring (14208-107)	1
* T10-319	Rear piston O-ring	2
T10-320	Plug O-ring	2
T10-324	Extension	1
T10-325	Spring retaining screw	1
T10-413	Felt	1
T10-414	Snap ring	1
T10-601	Air inlet	1
T10-602	Valve rod assembly	1
* T10-603	Air regulator assembly	1
* T10-604	Air regulator rod & nut	1
T10-605	Speed adjustment screw	1
* T10-606	Piston assembly	1
* T40-035	O-Ring (*14208-119)	1
* Included in Repair Kit 10-001 (17270)		

TP-10 Assemblies

Part No.	Description	Qty
T10-601	Air Inlet Assembly	
T10-102	Air inlet	1
T40-035	O-ring	1
T10-602	Valve Rod Assembly	
T3-325	O-ring	1
T10-310	Valve rod	1
T10-603	Air Regulator Assembly	
T10-318	O-ring	1
T10-401	Air regulator	1
T10-403	Urethane washer	1
T10-404	Washer	1
T10-408	Screw	2
T10-604	Air Regulator Rod & Nut	
T10-321	Nut	1
T10-402	Air regulator rod	1
T10-605	Speed Adjustment Screw	
T10-405	Speed adjustment screw	1
T10-407	O-ring	1
T10-606	Piston Assembly	
T3-325	O-ring	1
T10-302	Piston	1
T10-310	Valve rod	1
T10-311	Disc	2
T10-313	Spring	1
T10-314	Spring	1
T10-320	O-ring	2
T10-324	Extension	1
T10-325	Screw	1
T10-327	Gasket, disc	2

TP-10 PARTS DRAWING

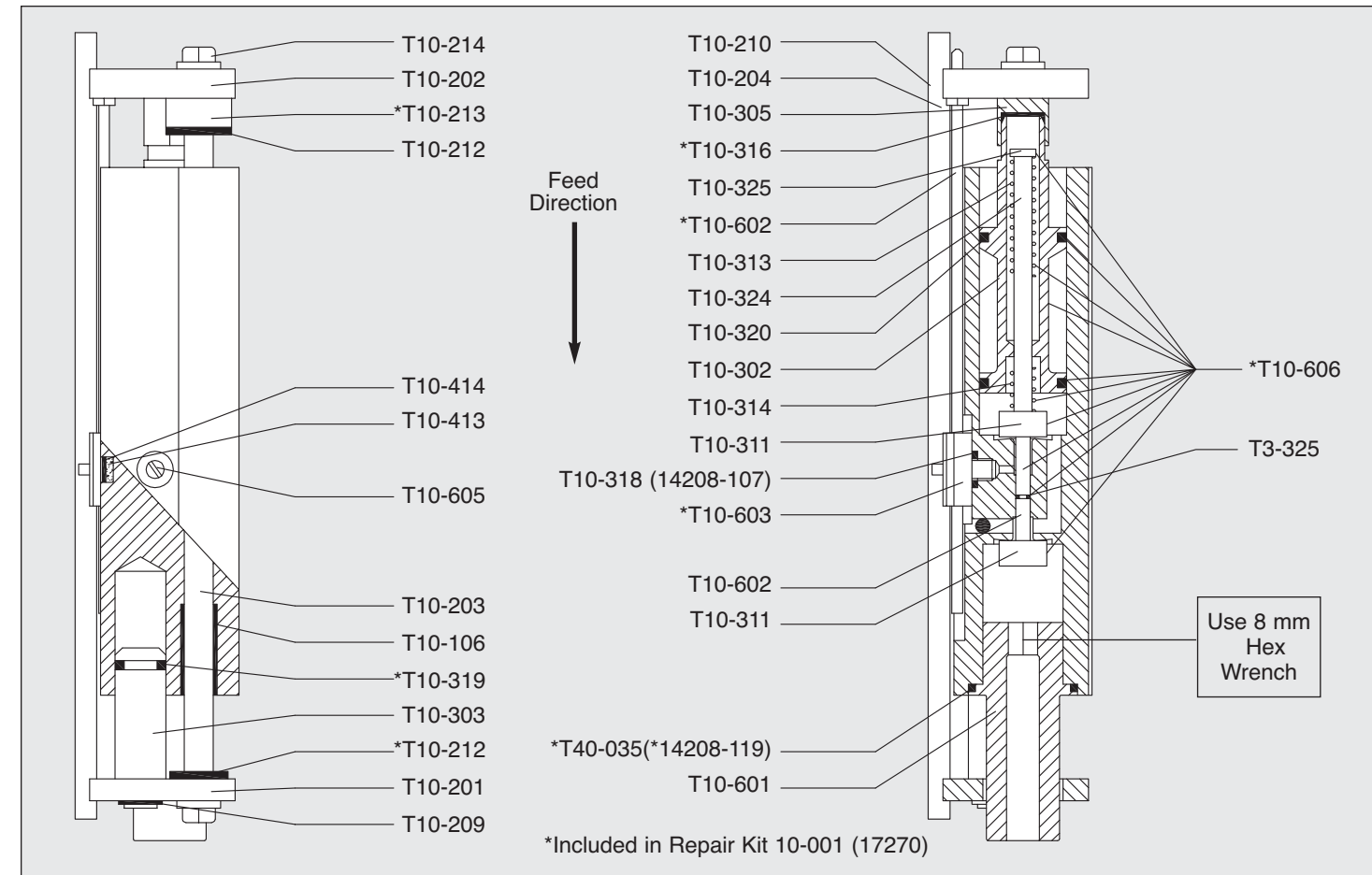

MODEL TP-40 SERVICE

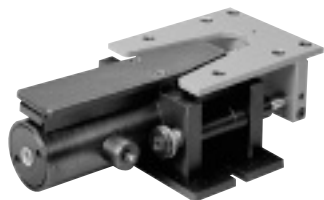

Factory Repair & Rebuild Service

Return the Transporter by UPS **Prepaid** to our repair center. After teardown and inspection, P/A Industries will notify you of the recommended cost for spare parts and labor.

Disassembly

1. Remove the Air Regulator Rod T40-029 by loosening the set screw in the top of the Slide Frame and slide the rod out. **If the slide is deformed, it must be replaced.**
2. Remove the two (2) Flathead Screws, which secure the Stop Washer T40-027 to the Slide Frame. Remove Nut T40-072 from back of Piston. Remove the Slide Frame.
3. Remove the Top Plate T40-006 which holds the Air Regulator T40-608 and Felt Cover T40-009. Check the Regulator O-Ring T3-407 (14208-008) for damage.
4. Remove the Air Line from Fitting T40-605. Remove the Plug T40-601 and check the Plug O-Ring T40-037.
5. Remove Air Inlet Cap. Check O-Ring for damage.
6. Remove the eight (8) Flathead Screws T10-210 from the bottom mounting plate and slide the Piston Housing away from the body.

7. Remove the Valve Disk T40-010 by unscrewing the Valve Disk Screw. Hold a 3mm hex wrench at the Valve Rod Washer T40-017 to prevent rotation. It is now possible to take out the Piston T40-019.
8. To remove the Valve Rod and Disk Assembly T40-603 from the Piston, hold the exposed Valve Disc gently in a vise. Use the 3mm Hex Wrench and remove the screw.
9. Replace the Long Valve Spring T40-047 and the Short Valve Spring T40-046.

Reassembly

Reassemble in reverse order, using caution not to bend the Valve Disc Assembly.

MODEL TP-40 DIMENSIONAL DRAWING

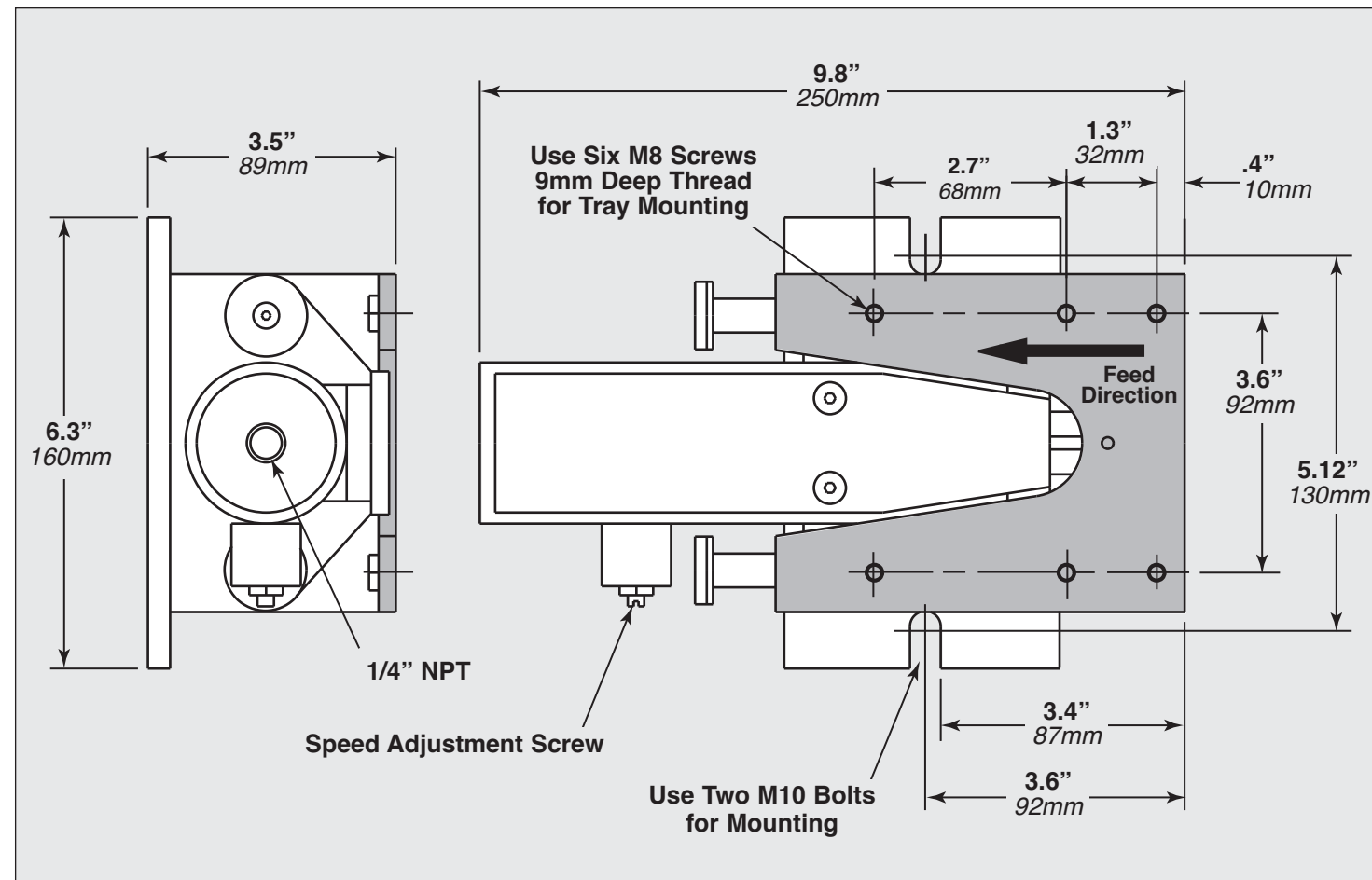

TP-40 Parts Description

Part No.	Description	Qty
T3-407	Regulator O-ring (14208-008)	1
T10-210	Flat head screw (6mm)	10
T10-605	Speed adjustment screw	1
T40-001	Foot	1
T40-006	Top plate	1
T40-008	Valve bar	1
T40-009	Felt cover	1
* T40-010	Valve disk	1
T40-011	Valve seat	1
T40-013	Disc	1
T40-017	Valve rod washer	1
T40-019	Piston	1
* T40-026	Bearing composite	4
T40-027	Stop washer	2
T40-028	Air inlet	1
T40-029	Air regulator rod	1
* T40-031	Small urethane washer	2
* T40-035	Piston O-ring (*14208-119)	2
* T40-036	Large O-ring (*14208-325)	1
* T40-037	Plug O-ring	1
T40-038	Guide pin	2
* T40-039	Valve rod cup seal	2
* T40-041	Piston cup seal	2
* T40-045	Compression spring	1
* T40-046	Short valve spring	1
* T40-047	Long valve spring	1
T40-049	Washer	2
* T40-050	Large urethane washer	4
T40-051	Air connection	2
T40-052	Tube	1
T40-055	Flat head screw (5mm)	3
T40-057	Set screw	1
T40-065	Felt	2
T40-068	Bushing, long	1
T40-069	Bushing, short	1
T40-071	Threaded mounting insert (8mm)	6
T40-072	Plug nut	1
T40-073	Threaded valve seat	1
* T40-074	Air inlet O-ring	1
T40-601	Plug assembly	1
T40-602	Cylinder front assembly	1
* T40-603	Valve rod assembly	1
T40-604	Slide frame assembly	1
T40-605	Air tube assembly	1
T40-606	Silencer assembly	1
T40-607	Speed adjustment assembly	1
* T40-608	Air regulator rod assembly	1
* Included in Repair Kit 40-001 (17271)		

TP-40 Assemblies

Part No.	Description	Qty
T40-601	Plug Assembly	
T40-018	Plug	1
T40-037	O-ring	1
T40-049	Washer	2
T40-050	Damper	2
T40-602	Front Cylinder Assembly	
T40-002	Front cylinder	1
T40-016	Sleeve	1
T40-024	Spacer	2
T40-026	Bearing composite	4
14208-325	O-ring	1
T40-603	Valve Rod Assembly	
T40-008	Valve bar	1
T40-013	Disc	1
T40-070	Extension	1
T40-030	Gasket, disc	1
T40-604	Slide Frame Assembly	
T40-014	Slide frame	1
T40-031	Small urethane washer	2
T40-038	Guide column	2
T40-042	Snap ring	2
T40-054	Screw	2
T40-057	Set screw	1
T40-071	Mounting insert	6
T40-605	Air Tube Assembly	
T40-051	Air connection	2
T40-052	Tube	1
T40-606	Silencer Assembly	
T40-059	Mantel	1
T40-067	Washer	1
T40-607	Speed Adjustment Assembly	
T10-407	O-ring	1
T10-405	Screw	1
T40-060	Valve	1
T40-608	Air Regulator Rod Assembly	
T3-407	O-ring	1
T40-029	Air regulator rod	1
T40-058	Air regulator	1

TP-40 PARTS DRAWING

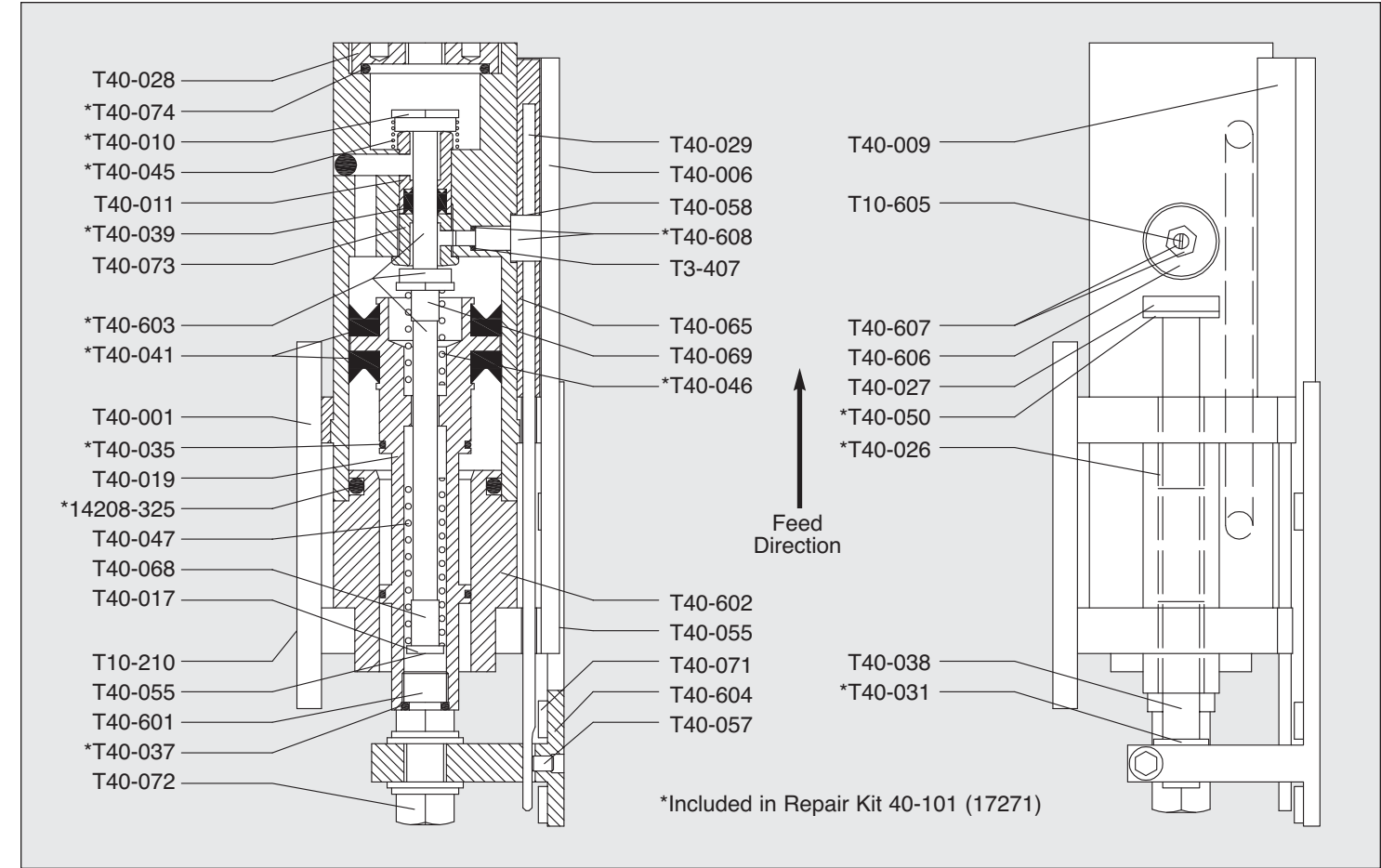

MODEL TP-70 SERVICE

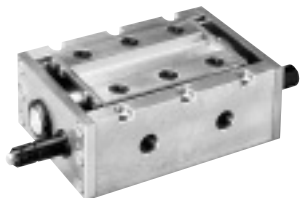

Factory Repair & Rebuild Service

Return the Transporter by UPS **Prepaid** to our repair center. After teardown and inspection, P/A Industries will notify you of the recommended cost for spare parts and labor.

Disassembly

1. Remove the Spanner Nut T70-216 from the Rear Piston T70-601 and push the Piston inside the Cylinder.
2. Remove the eight (8) holder screws with a T40 Torx wrench. Loosen the eight (8) Set Screws T70-436. There is no need to remove the set screws.
3. Pull the Front and Rear Holders away from the Body while holding the Outer Guide Assemblies to prevent the Bearings from being lost. The Front Piston T70-602 and Shock Absorber T70-407 will come out with the Front Holder. The Speed Adjustment Assembly will come out with the Rear Holder.
4. Now remove the Front and Rear Retaining Plates. The Rear Piston can now be removed from the Body.
5. Back out the Speed Adjustment Valve Locking Screw T70-311 and remove the Speed Adjustment Valve T70-604.

6. Unscrew Valve Seals T40-010 and pull the seals out. Check all seals and O-rings for wear, make sure valve seals are flat, and Valve Rod T70-603 is straight.

Reassembly

When reassembling, take care with the following:

1. Install Speed Adjustment Valve and align indent for the Speed Adjustment Valve Locking Screw.
2. Remember to install the Front and Rear Cylinder Urethane Washers T70-257 and T70-259.
3. Use the T70-436 Set Screws to adjust out any play or looseness in the Slide Assembly before tightening the Holder Screws.

MODEL TP-70 DIMENSIONAL DRAWING

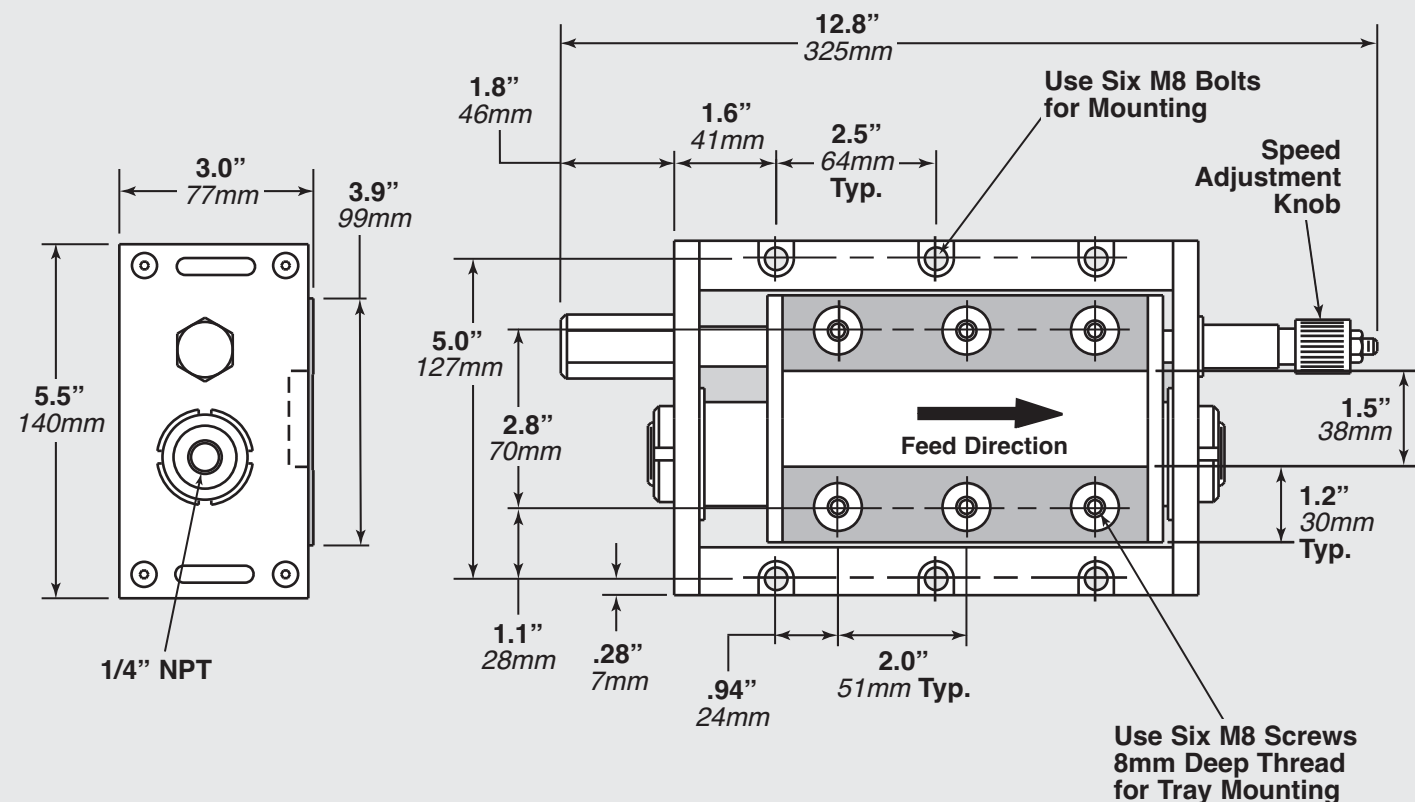

TP-70 Parts Description

Part No.	Description	Qty
T3-407	Cylinder rod O-ring (14208-008)	2
* T10-319	Speed adjustment knob O-ring	1
* T10-320	Plug O-ring	1
* T40-010	Valve seals	2
* T40-037	O-ring	1
* T40-045	Compression spring	1
* T40-047	Compression spring long assembly	2
T70-105	Threaded mounting insert (8mm)	6
T70-153	Bearing retainer (5mm)	2
T70-154	Ball bearing (5mm)	56
* T70-215	Cup seal (front & rear)	2
T70-216	Spanner nut (front & rear)	2
T70-217	Snap ring	2
* T70-220	Piston urethane washer	2
T70-253	Rear spring guide	1
T70-254	Front spring guide	1
* T70-257	Front cylinder urethane washer	1
* T70-259	Rear cylinder urethane washer	1
T70-302	Speed adjustment rod	1
T70-303	Speed adjustment knob	1
* T70-306	Speed adjustment valve O-ring, small (*14208-011)	1
T70-310	Knob locking nut	1
T70-311	Speed adjustment valve lock screw	1
T70-320	Washer	1
T70-321	Rear threaded bushing	1
T70-322	Silencer	1
T70-403	Rear retaining plate	1
T70-404	Front retaining plate	1
T70-406	Front threaded bushing	1
T70-407	Shock absorber	1
T70-408	Shock absorber locking nut	1
T70-410	Holder screw	8
T70-411	Retaining plate screw	12
T70-413	Shock absorber plug	1
T70-433	Rear holder	1
T70-434	Front holder	1
T70-436	Screw	8
T70-601	Rear piston assembly	1
T70-602	Front piston assembly	1
* T70-603	Valve Rod assembly	1
T70-604	Valve assembly	1
T70-605	Ball guide assembly	1
* Included in Repair Kit 70-001 (17272)		

TP-70 Assemblies

T70-601	Rear Piston Assembly	Qty
T40-047	Spring, long	1
T70-211	Rear piston	1
T70-215	Cup seal	1
T70-217	Snap ring	1
T70-253	Rear spring guide	1

T70-602	Front Piston Assembly	Qty
T40-047	Spring, long	1
T70-212	Front piston	1
T70-215	Cup seal	1
T70-217	Snap ring	1
T70-254	Front spring guide	1

T70-603	Valve Rod Assembly	Qty
T3-407	O-ring	2
T70-251	Valve rod	1

T70-604	Valve Assembly	Qty
T40-037	O-ring	1
T70-302	Valve rod	1
T70-306	O-ring	1
T70-308	Valve	1

T70-605	Ball Guide Assembly	Qty
T70-153	Ball retainer (5mm)	1
T70-154	Ball (5mm)	28
T70-426	Ball guide	1
T70-428	Screw	7
T70-435	Guide column	1
T70-437	Ball guide	1

TP-70 PARTS DRAWING

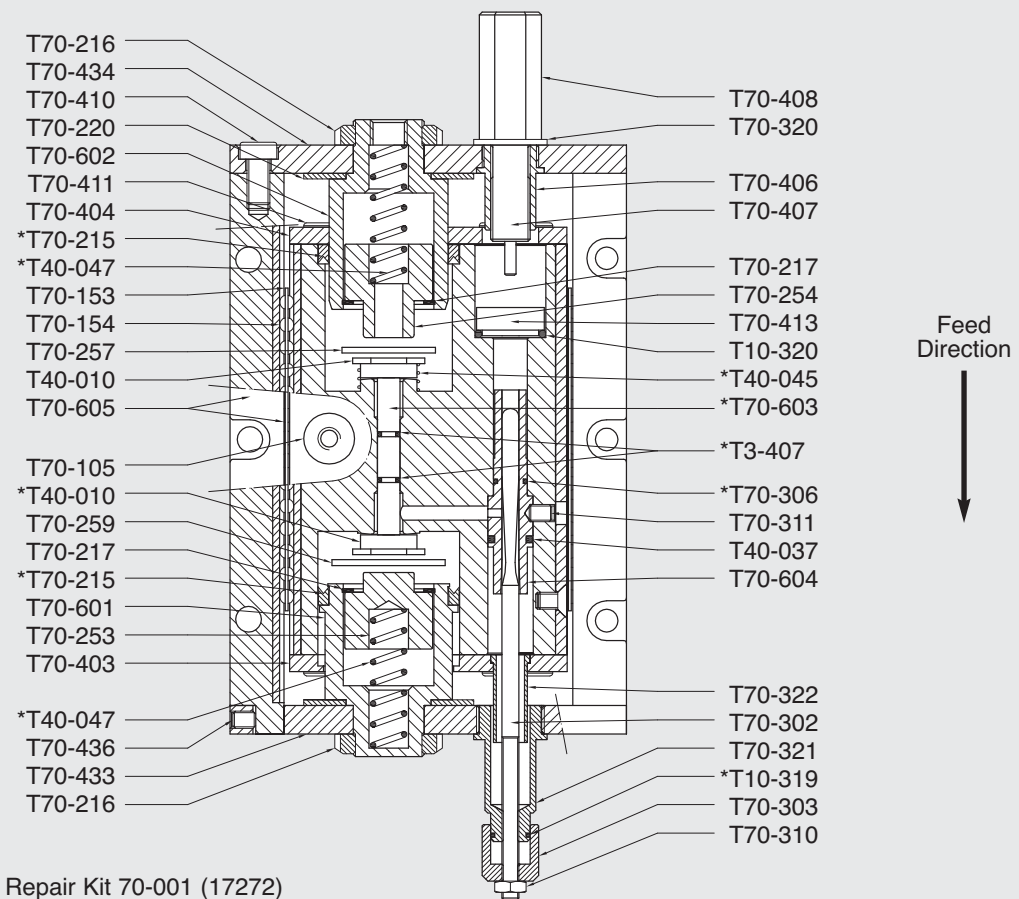

*Included in Repair Kit 70-001 (17272)

MODEL TP-140 SERVICE

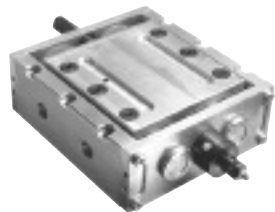

Factory Repair & Rebuild Service

Return the Transporter by UPS **Prepaid** to our repair center. After teardown and inspection, P/A Industries will notify you of the recommended cost for spare parts and labor.

Disassembly

1. Remove the two (2) Spanner Nuts T70-216 from the Rear Piston assembly T70-601 and T140-211 and push the Pistons inside the Cylinder.
2. Remove the eight (8) holder screws with a T40 Torx wrench. Loosen the eight (8) Set Screws T70-436. (No need to remove).
3. Pull the Front and Rear Holders away from the Body while holding the Outer Guide Assemblies to prevent the Bearings from being lost. Remove the Front Piston assembly T70-602 and Rear Piston T140-212. Together, with the two (2) Shock Absorbers T70-407, they will come out with the Front Holder. The Speed Adjustment Assembly will come out with the Rear Holder.
4. Now remove the Front Retaining Plate T140-404. The Rear Piston can now be removed from the Body.

5. Unscrew Sleeve T140-326 using an 8 mm Hexagon Wrench. Then pull out the Speed Adjustment Valve T140-308.
6. Unscrew Valve Seals T40-010 and pull out. Check all seals and o-rings for wear, make sure Valve Seals are flat, and Valve Rod T70-603 is straight.

Reassembly

When reassembling, take care with the following:

1. Install the Speed Adjustment Valve T140-308 and tighten Sleeve T140-326 using an 8 mm Hexagon Wrench. Do not overtighten.
2. Don't forget to install the Front and Rear Cylinder Urethane Washers T70-257 and T70-259.
3. Use the T70-436 Set Screws to adjust out any play or looseness in the Slide Assembly before tightening the Holder Screws.

MODEL TP-140 DIMENSIONAL DRAWING

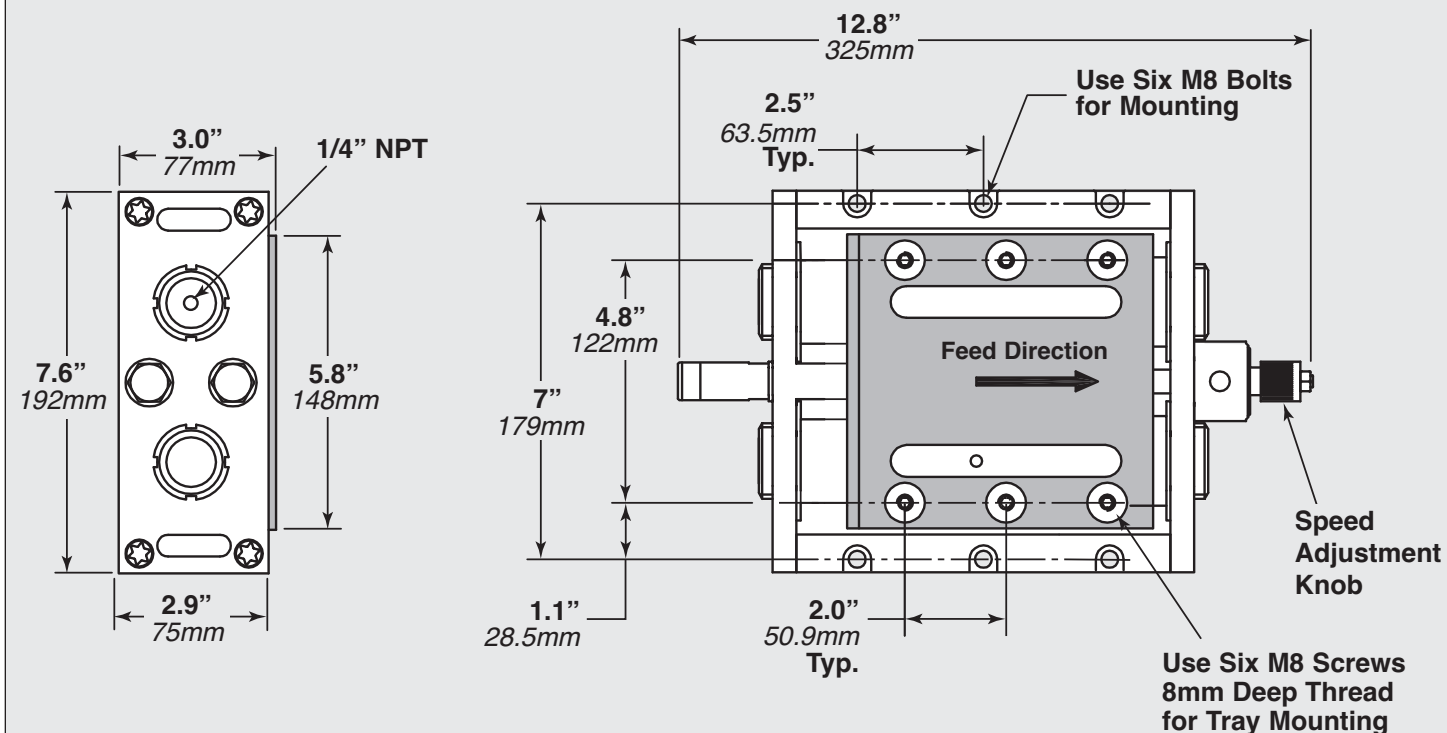

TP-140 Parts Description

Part No.	Description	Qty
T3-407	Cylinder rod O-Ring (14208-008)	2
* T10-319	Speed adjustment knob O-Ring	1
* T10-320	Plug O-ring	2
* T40-010	Valve seals	2
* T40-045	Compression spring	2
* T40-047	Valve spring	2
T70-153	Bearing retainer (5mm)	2
* T70-215	Cup seal (front & rear)	4
T70-216	Spanner nut (front & rear)	4
T70-217	Snap ring	2
* T70-220	Piston urethane washer	4
T70-253	Rear spring guide	1
T70-254	Front spring guide	1
T70-303	Speed adjustment knob	1
T70-310	Knob locking nut	1
T70-320	Washer	2
T70-406	Front threaded bushing	2
T70-407	Shock absorber	2
T70-408	Shock absorber locking nut	2
T70-411	Retaining plate screw	8
T70-413	Shock absorber plug	2
T70-436	Screw	8
T70-601	Front piston assembly	1
T70-602	Rear piston assembly	1
* T70-603	Valve rod assembly	1
T70-605	Ball guide assembly	1
T140-105	Threaded mounting insert (8mm)	6
T140-211	Front piston	1
T140-212	Rear piston	1
T140-302	Speed adjustment Rod	1
T140-308	Speed adjustment valve	1
T140-326	Sleeve	1
T140-401	Rear holder	1
T140-402	Front holder	1
T140-404	Front retaining plate	1
T140-601	Front piston assembly	1
T140-602	Rear piston assembly	1
T140-603	Silencer assembly	1
* Included in Repair Kit 140-001 (18914)		

TP-140 Assemblies

Part No.	Description	Qty
T140-601	Rear Piston Assembly	
T140-211	Rear piston	1
T70-215	Cup seal	1
T140-602	Front Piston Assembly	
T140-212	Front piston	1
T70-215	Cup seal	1
T140-603	Silencer Assembly	
T140-324	Damp bushing	1
T140-502	Lock	1
T140-503	Silencer	1
T140-504	Felt	1
T40-045	Spring	1
T70-601	Front Piston Assembly	
T40-047	Spring, long	1
T70-211	Front piston	1
T70-215	Cup seal	1
T70-217	Snap ring	1
T70-253	Spring guide	1
T70-602	Rear Piston Assembly	
T40-047	Spring, long	1
T70-212	Rear piston	1
T70-215	Cup seal	1
T70-217	Snap ring	1
T70-254	Spring guide	1
T70-603	Valve Rod Assembly	
T3-407	O-ring	2
T70-251	Valve rod	1
T70-605	Ball Guide Assembly	
T70-153	Ball retainer (5mm)	1
T70-154	Ball (5mm)	28
T70-426	Ball guide	1
T70-428	Screw	7
T70-435	Guide column	1
T70-437	Ball guide	1

TP-140 PARTS DRAWING

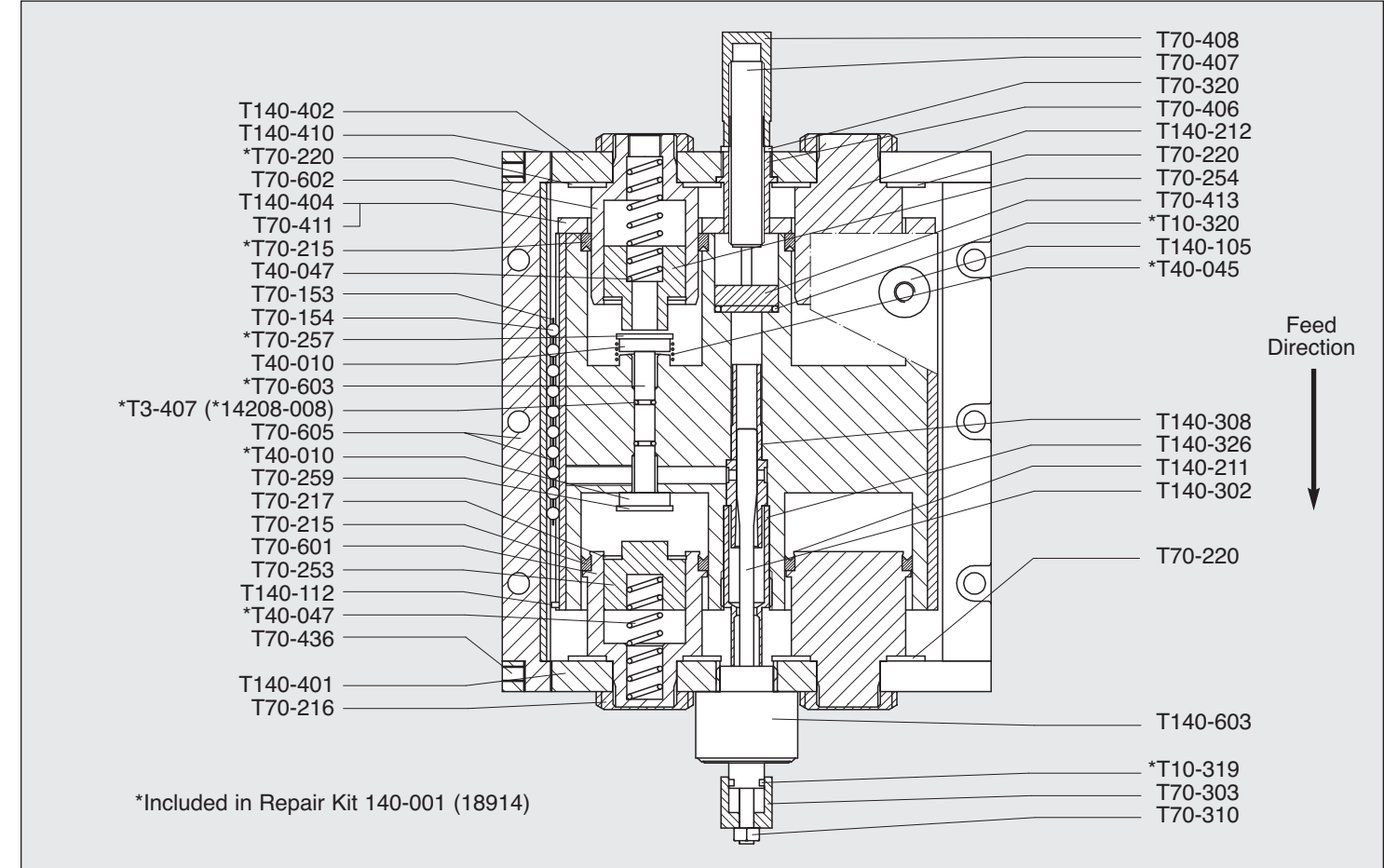

TECHNICAL DATA

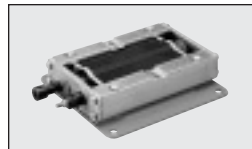

Model	Air Consumption	Rate of Feed	Sound Level	Weight	Transportation capacity	Max. weight Tray
TP-3	8.8 cfm	29-33 fpm	56 dB (A)	3 lbs	6.4 lbs	3.2 lbs
	5 L/min	8-10 m/min	56 dB (A)	1,4 kg	3 kg	1,5 kg

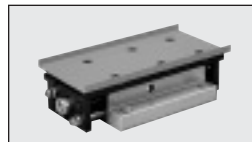

TP-10	19.4 cfm	29-33 fpm	60 dB (A)	6 lbs	21.4 lbs	6.4 lbs
	11 L/min	8-10 m/min	60 dB (A)	2,8 kg	10 kg	3 kgs

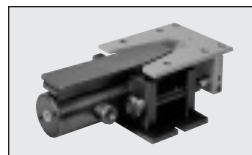

TP-40	55 cfm	29-33 fpm	70 dB (A)	15 lbs	85.6 lbs	32 lbs
	31 L/min	8-10 m/min	70 dB (A)	7,2 kg	40 kg	15 kg

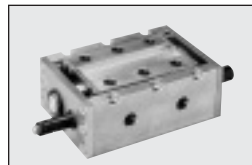

TP-70	78 cfm	29-33 fpm	68 dB (A)	12 lbs	150 lbs	107 lbs
	44 L/min	8-10 m/min	68 dB (A)	5,5 kg	70 kg	50 kg



TP-140	74 cfm	29-33 fpm	62 dB (A)	17 lbs	300 lbs	214 lbs
	42 L/min	8-10 m/min	62 dB (A)	8 kg	140 kg	100 kg

Air consumption is measured at a pace of 120 strokes per minute and an air pressure of 4 bars (60psi).

Air Pressure is 60-80 psi (4-5,5 bar).

Length of Stroke is 1 in. (23 mm).

Rate of Feed is 29-33 fpm (8-10 m/min).

Max. incline of Feed Tray is 8°.

Roller Slide Tray Support Options

Model RS-1
#17918

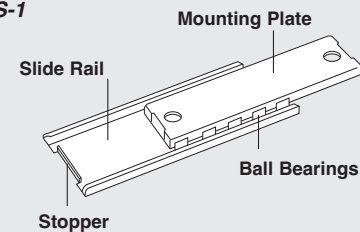

Model RS-2
#17432-01

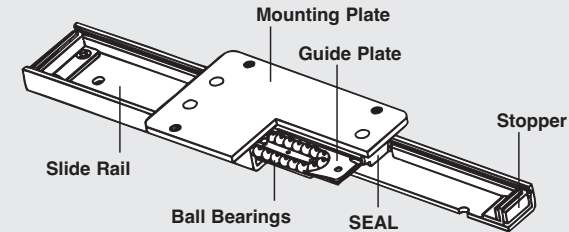

Roller Slide Dimensions

Model RS-1
#17918

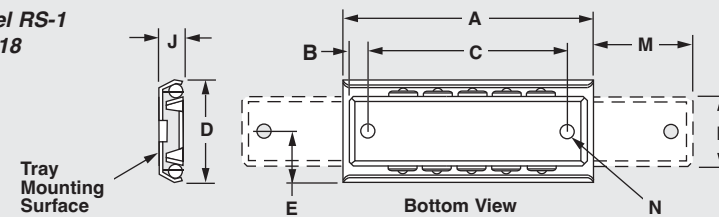

Model RS-2 #17432-01

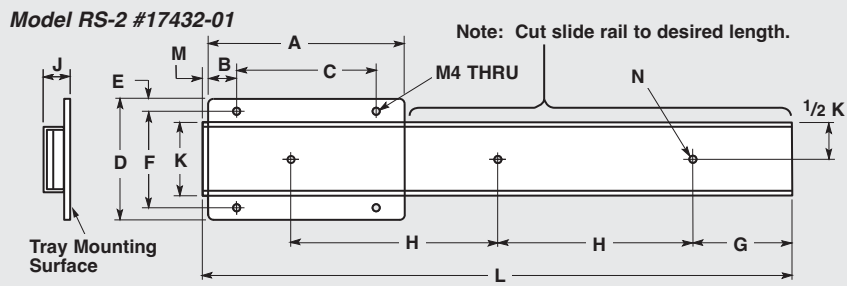

	METRIC - mm		USA - inches	
	RS-1	RS-2	RS-1	RS-2
A	105	100	4.20	3.94
B	6.8	15	.27	0.59
C	86	70	3.38	2.76
D	35	60	1.375	2.36
E	35	5	.68	0.20
F	-	50	-	1.97
G	-	50	-	1.97
H	-	100	-	3.94
J	9.5	16.2	.375	0.64
K	24	37	.93	1.46
L	-	300	-	11.8
M	32 Max	2.3	1.25 Max	0.09
N	4.5	4.6 x 5.3	.175	0.18 x 0.21